



UNIVERSITEIT•STELLENBOSCH•UNIVERSITY
jou kennisvenoot • your knowledge partner

UKUNAKEKELWA KOMUNTU ONESIFO SOHLANGOTHI

EKHAYA



Ihlanganiswe futhi yahlelwa ngu-ES Scheffler & SJ Visagie

ISikhungo Sezifundo Zokwelashwa Kwabantu Abanokukhubazeka, saseNyuvesi yase-Stellenbosch

Igama:

Umqeqeshi/umelaphi:

Inombolo yocingo:



UNIVERSITEIT•STELLENBOSCH•UNIVERSITY
jou kennisvenoot • your knowledge partner

Ilungelo lombhali © 2011 INyuvesi yase-Stellenbosch. Wonke amalungelo agodliwe. Ushicilelo olubuyekeziwe © 2015 INyuvesi yase-Stellenbosch. Wonke amalungelo agodliwe.

**Ilungelo lombhali ushicilelo lwesiZulu © 2015
INyuvesi yase-Stellenbosch. Wonke amalungelo agodliwe.**

Leli bhukwana lingumkhiqizo weSikhungo Sezifundo Zokwelashwa Kwabantu Abanokukhubazeka, saseNyuvesi yase-Stellenbosch.

Ligaywe futhi lakhizwa eNingizimu Afrika.

Ushicilelo lwe-inthanethi: Imigomo yokulusebenzisa

1. Lolu shicilelo lwe-inthanethi lunombandela wokuthi uma lukhiqizwa kabusha noma lusatshalaliswa, noma lugcinwa noma lusakazwa, lokho kumele kwenziwe ngokuphelele, kungabi khona nelilodwa ikhasi elishiywa ngaphandle.
2. Abasebenzisi balolu shicilelo lwe-inthanethi bangalukhiqiza kabusha futhi balusabalalise njengebhukwana eliyiphepha noma njengebhukwana elifundwa kwikhompyutha kodwa lokho kumele bakwenze ngaphansi kwale mibandela elandelayo:
 - i Wonke amakhasi aleli bhukwana, kubandakanya nekhasi langaphambili kanye nekhasi langemuva, kumele ngaso sonke isikhathi abe yingxenye yalawo makhasi akhiqizwa kabusha noma asatshalaliswayo.
 - ii Akuvumelekile ukuthi amakhophi alolu shicilelo lwe-inthanethi athengiswe ngenhloso yokuzitholela inzuzo.
 - iii Ayikho ingxenye yalolu shicilelo lwe-inthanethi engaguqulwa noma ishintshwe nganoma iyiphi indlela ngaphandle kokuthola kuqala imvume ebhalwe phansi yomnikazi wamalungelo aleli bhukwana.

**Imibuzo noma imibono kumele ithunyelwe
kumnikazi wamalungelo ale
libhukwana kuleli kheli:**

Head of Department
Centre for Rehabilitation Studies
Stellenbosch University
PO Box 241
Cape Town
8000

South Africa

Inombolo yocingo: +27 21 938 9528
Ifeksi: +27 21 931 9835
Iimeyili: CRS@sun.ac.za

Okuqukethwe

1. Izinto ezisemqoka okumele uzazi mayelana nesifo sohlangothi	2
2. Izinkinga eziphathelene nezokuxhumana	4
3. Izinkinga eziphathelene nengqondo (ukucabanga) kanye nokuziphatha	7
4. Indlela okumele ahlale/alale ngayo umuntu ohlaselwe yisifo sohlangothi	9
5. Ukudla, ukugwinya kanye nokunakekelwa kwamazinyo/komlomo	15
6. Ukunakekelwa kwamahlombe	21
7. Ukunyakazisa nokuphendula umuntu embhedeni	25
8. Ukususa umuntu umbeke kwenye indawo (ukumsusa embhedeni umbeke esihlalweni)	31
9. Ukuzinakekela komuntu ngokwakhe	37
10. Ukuhambahamba ngokulekelelwa ngomunye umuntu	51
11. Izinkinga ezivamile emva kokuhlaselwa yisifo sohlangothi	52
Amazwi okubonga	53
Kungani sibhale leli bhukwana?	54

1. Izinto ezisemqoka okumele uzazi mayelana nesifo sohlangothi

? Yini isifo sohlangothi?

Isifo sohlangothi sibangelwa ukuba khona kwezinkinga eziphathelene nokuhamba kwegazi emzimbeni ngenkathi liya engxenyeni ethile yobuchopho. Lezi zinkinga kungenzeka kube ngeyodwa kulezi ezilandelayo:

- Kungenzeka kube khona umonakalo noma isifo esinciphisa umthambo wegazi noma esivimbela ukuhamba kwegazi emthanjani. Ukuvimbeleka kwegazi kusho ukuthi i-oksijini (umoya esiwuphefumulayo) kanye nezondlamzimba (ukudla) ngeke kusafinyelele ezingxenyeni ezithile zobuchopho. Lokhu kudala umonakalo kulezo zingxenye futhi kuholela ekutheni ziyeke ukusebenza.
- Kuyenzeka uqhume umthambo wegazi. Lokhu kuholela ekutheni igazi lichithekele ebuchosheni bese lidala umonakalo.

? Ngabe abantu bayalulama emva kokuhlaselwa yisifo sohlangothi?

Leso naleso sifo sohlangothi sihlukile kwezinye. Umthelela waso uzoya ngokuthi iyiphi ingxenye yobuchopho elimele.

- Ngokuvamile, abantu abahlaselwe yisifo sohlangothi bayalulama kancane kancane esikhathini eside, kodwa esikhathini esiningi abalulami ngokuphelele.
- Abanengi bagcina sebefundile futhi ukuzihambela ngezinyawo zabo, kodwa bahamba kancane futhi bawa kalula.
- Abanengi bagcina bengasakwazi ukunyakazisa wonke amalunga omzimba noma ukulawula izandla nezingalo zabo ngendlela ababekwazi ukuzilawula ngayo ngaphambi kokuhlaselwa yisifo sohlangothi.
- Ezinye izicubu zomzimba zikhubazeka unomphela noma zibe ntekenteke, futhi ezinye ziyagongobala, ziqine. Lokhu kwenza ukuthi kube nzima kubantu abahlaselwe yisifo sohlangothi ukuthi bakwazi ukunyakaza kahle kanye nokulawula imizimba yabo.
- Abanye abantu bagcina sebekwazi ukunyakazisa nokulawula imizimba yabo cishe ngokujwayelekile.
- Abanye abantu bayaqhubeka nokuba nezinkinga eziphathelene nokusebenza kwengqondo (njengokucabanga, ukuthatha izinqumo kanye nokwazi ukuthi kumele bagweme ingozi).

? Ngabe imithi iyaselapha isifo sohlangothi?

Kuyinto engeke yenzeke ukuthi izinhlayiya-kuphila zobuchopho (brain cells) esezifile zikwazi ukusebenza futhi. Kodwa uma welapha izinkinga zezempilo ezibangele isifo sohlangothi ungaswema ukuthi umuntu aphinde futhi ahlaselwe yisifo sohlangothi. Izinkinga zezempilo ezivamisile ezibanga isifo sohlangothi yisifo sikashukela (ushukela omningi ngokweqile egazini), umfutho wegazi ophakeme, ikholesteroli ephakeme (amafutha amaningi ngokweqile egazini) kanye nezinkinga eziphathelene nokusebenza kwenhliziyi. Umuntu ohlaselwe yisifo sohlangothi kumele abonane nodokotela ukuze elashelwe lezi zifo futhi axilongwe ukuze kubhekwe ukuthi azikho yizi ezinye izinkinga emzimbeni.



Yiziphi izinkinga abavamise ukuhlangabezana nazo abantu emva kokuhlaselwa yisifo sohlangothi?

Abantu kuyenzeka bahlangabezane nalezi zinkinga ezilandelayo emva kokuhlaselwa yisifo sohlangothi:

- Ukuba ntekenteke noma ukukhubazeka kohlangothi olulodwa lomzimba
- Ukuqina nokugongobala kwengalo, isandla kanye/noma umlenze
- Ubunzima bokuhlala ngezinqe noma bokuma ngezinyawo kahle, ukuwa kalula uma uhleli noma umile
- Ubunzima bokukhuluma noma bokuqonda ulimi olukhulunywayo
- Ubunzima bokulawula isinye noma ukuzithuma (izidingo zasendlini yangasese) (kodwa-ke lokhu kuvamise ukuba ngcono ngokuhamba kwesikhathi)
- Ukungasebenzi kwemizwa yohlangothi lomzimba olubuthakathaka
- Babonakala sengathi bayakhohlwa ngohlangothi lomzimba olubuthakathaka noma bangalunaki
- Izinkinga eziphathelene namehlo (ukubona)
- Babonakala sengathi badidekile futhi bakuthola kunzima ukukhumbula izinto
- Banenhliziy o encane, futhi nendlela abaziphatha ngayo iyaguquguquka
- Bayakhohlwa ukuthi yenziwa kanjani imisebenzi yabo yansukuzonke



Kumele ngimphathe kanjani umuntu ohlaselwe yisifo sohlangothi?

- Kumele achithe isikhathi esincane kakhulu embhedeni. Ukuchitha isikhathi esiningi embhedeni kuzomenza abe buthakathaka kakhulu kunakuqala. Esikhundleni sokumvumela ukuthi alale embhedeni isikhathi eside kumele umnikeze isikhashana esincane sokuhlaba ikhefu ngokuthi acambalale ngezikhathi ezithile.
- Kumele umvuse ngesikhathi sakhe esijwayelekile, ageze bese egqoka.
- Kumele azibandakanye nomndeni wonke ngokujwayelekile ngesikhathi sokudla.
- Kumele uzame ukumelekelela ukuthi alandele inqubo ehlelekile yansukuzonke yokwe nza izinto.
- Kumele umkhuthaze ukuthi azijwayeze ukuzenzela izinto ngokwakhe. Mbekezelele futhi umnike isikhathi esithe xaxa sokuphuthula imisebenzana yakhe kanye nokuzijwayeza imisebenzana okumele ayenze. Kuwumkhuba omuhle ukuthi azenzele imisebenzana yakhe yansukuzonke futhi azijwayeze le misebenzi.
- Khumbula ukuthi umuntu ohlaselwe yisifo sohlangothi ngumuntu omdala; ungalokothi umphathe sengathi uyingane.

2. Izinkinga eziphathelene nezokuxhumana

? Yini ezokuxhumana?

Ezokuxhumana yindlela esabelana ngayo ngolwazi ngokukhuluma, ngokusebenzisa izimpawu zezandla, ngokubhala kanye nezinye izindlela, kanye nekhono lethu lokuqonda lolo lwazi.

? Yiziphi izinkinga zokuxhumana abavamise ukuhlangabezana nazo abantu abahlaselwe yisifo sohlangothi?

Abantu abanesifo sohlangothi kuyenzeka bahlangabezane nalezi zinkinga ezilandelayo:

- Ukungezwa ezindlebeni noma ubunzima bokuzwa. Kwesinye isikhathi lokhu kubangelwa ukukhula komuntu ngokweminyaka, ngakho-ke akuyona into ebangelwa yisifo sohlangothi ngaso sonke isikhathi. Kungenzeka umhlengikazi emtholampilo ahlole ukuthi ayikho yini into evimbile kwingxenye engaphandle yendlebe (ingxenye engaxilongwa ngamehlo), njengesigonogono.
- Ubunzima bokuqonda into eshiwoyo
- Bayahluleka ukuhlela inkulumo (ukuhlanganisa imisindo efanelekile ukuze kwakheke amagama)
- Bayahluleka ukuthola noma ukucabanga amagama afanelekile
- Bayahluleka ukulawula amalunga omzimba asilekelelayo ukuthi sikwazi ukwakha noku-phimisa amagama, njengolimu kanye nezicubu zomhlathi
- Bayahluleka ukufunda, ukubhala kanye nokuqonda izithombe
- Bayahluleka ukukhuluma ngezwi eliphakeme

? Ngingabhekana kanjani nalezi zinkinga zokuxhumana?

Uma ukhuluma nomuntu ohlaselwe yisifo sohlangothi kumele:

- Uguqule ubuso bakho bubheke ngakuyena.
- Umbheke emehlweni.
- Ube seduze kwakhe.
- Ukhulume ngokunensa futhi ngokucacile, ikakhulu uma umuntu onesifo sohlangothi ekhathele.
- Usebenzise izwi lakho elijwayelekile. Ungamemezi.
- Ukuphinde lokho okushilo uma engakuqondi.
- Usebenzise imisho emifushane.
- Ungayilandelanisi eduzane kakhulu imisho.
- Usebenzise izimpawu zezandla ngenkathi ukhuluma (umkhombise ngezandla).
- Ukhulume ngezihloko zansukuzonke, ezijwayelekile.
- Uma engakwazi ukukhuluma mbuze imibuzo elula angayiphendula ngokuthi nje 'yebo' noma 'cha'.
- Uma ungenaso isiqiniseko sokuthi uyakuqonda lokho okushilo, mcele ukuthi akuphindele ulwazi olubalulekile lwalokho omtshele kona.

Ngenkathi ulalele lokho okushiwo ngumuntu ohlaselwe yisifo sohlangothi kumele:

- Umbekezelele.
- Ubheke izindebe zakhe.
- Umkhumbuze ukuthi akhulume ngokunensa futhi ngokucacile.
- Umkhumbuze ukuthi kumele agxilise umqondo kulokho akushoyo ngenkathi esebenzisa amagama alukhuni.
- Umcele ukuthi aphinde uma ungakuqondi lokho akushilo. Ungashayi sengathi uyakuqonda lokho akushilo.
- Umkhuthaze ukuthi asebenzise amabizo abangane bakhe kanye nawamalunga omndeni wakhe.
- Umkhuthaze ukuthi asebenzise amagama alula njengegama elithi 'sawubona' noma elithi 'ngiyabonga'.
- Uma engakwazi ukukhuluma, mkhuthaze ukuthi asebenzise izimpawu zezandla futhi akhombe izinto.

Okujwayelekile:

- Kumele uqinisekise ukuthi akunamsindo eduzane.
- Nciphisa umsindo kamabonakude noma womsakazo.



Yikuphi okunye engingakusebenzisa ukulekelela kwezokuxhumana?

A	B	C	D	E	F	G
H	I	J	K	L	M	N
O	P	R	S	T	U	V
W	Q	1	2	3	4	5
6	7	8	9	10	Yes	No

Sebenzisa ibhodi lama-alfabhethi. Abanye abantu abahlaselwe yisifo sokuwa bayakwazi ukupela amagama alokho abakufunayo.



Sebenzisa ishadi (iphosta) elinezithombe kanye/noma amagama.

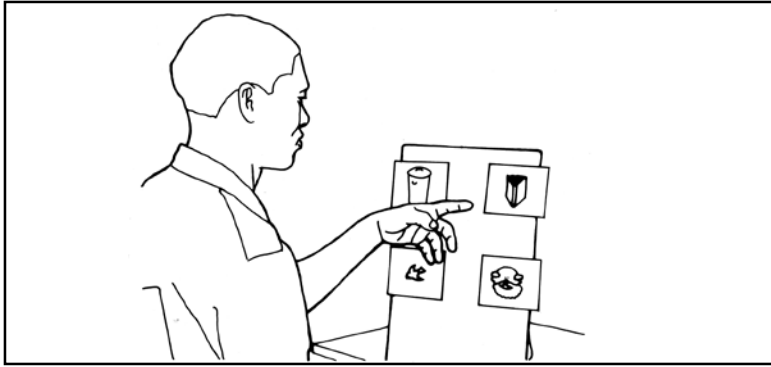

Sebenzisa izithombe.



Sebenzisa izimpawu
zezandla.

3. Izinkinga eziphathelene nengqondo (ukucabanga) kanye nokuziphatha

? Yiziphi izinkinga ezingenzeka eziphathelene nengqondo kanye nokuziphatha komuntu ohlaselwe yisifo sohlangothi?

Ngenxa yomonakalo owenzeke ebuchosheni babo, abanye abantu abahlaselwe yisifo sohlangothi bakuthola kunzima ukukhumbula noma ukuqonda izinto. Abanye bakuthola kunzima ukulawula imizwa yabo kanye nokulangazelela (izidingo), futhi baziphatha ngendlela exakile. Kodwa-ke akubona bonke abantu abahlaselwe yisifo sohlangothi abanalezi zinkinga. I-occupational therapist † (umelaphi wezifo eziphathelene nokusebenza komzimba nengqondo, owelapha lokhu ngenhloso yokubuyisela umzimba esimweni sawo ukuze umuntu aphile impilo yakhe yansukuzonke abeyiphila ngaphambi kokuhlaselwa ukugula noma ukulimala) angahlola ukuthi umuntu ohlaselwe yisifo sohlangothi unazo yini lezi zinkinga.

? Yiziphi izimpawu zaleli zinkinga?

Kungenzeka uphawule lokhu okulandelayo:

- Ukudideka: Akakwazi ukubona nokukhumbula abantu abaziyo, akazi ukuthi ukuphi (indawo) noma akazi ukuthi isikhathi sini futhi akakwazi ukusho ukuthi namhlanje yiluphi usuku lwenyanga kanye nonyaka.
- Izinkinga eziphathelene nokukhumbula izinto ezenzeke esikhathini esifushane esedlule: Isibonelo, akasayikhumbuli into eshiwo esikhathini esiyihora esedlule.
- Akukho akwenzayo uma engakatshelwa ukuthi akwenzelwe: Isibonelo, uyaqhubeka nje azilalele embhedeni uma engakatshelwa ukuthi makavuke.
- Ukuthola kunzima ukwenza imisebenzana elula: Umsebenzana ofana nokuzigqokisa ijezi uba ngumsebenzi olukhuni kakhulu kuyena.
- Uyahleleka ukuzithiba (isibonelo, unolaka noma unenhliziyi encane, akakwazi ukulawula inkandatho yocansi noma ukulangazelela ukudla): Kungenzeka enze izinto ngokuxhamazela, ngaphandle kokucabanga.
- Uziphatha ngendlela engalungile: Isibonelo, kuyenzeka ahleke ngenkathi umuntu othile elimala.
- Ufuna ukunakwa: Isibonelo, umuntu ohlaselwe yisifo sohlangothi kungenzeka afune ukuthi umnaka noma umsize ngokushesha futhi ngaso sonke isikhathi.
- Ulushaya indiva/akalunaki uhlangothi lomzimba wakhe olubuthakathaka: isibonelo uma kukhona into ayithungathayo akazihluphi nakancane ngokubheka ngasohlangothi lomzimba wakhe olubuthakathaka.
- Akayiqondi imali noma akayiqondi ukuthi isetshenziswa kanjani.
- Unengcindezi yomphefumulo/unomuzwa wokudangala okukhulu futhi uhlala 'edumele futhi umoya wakhe uphansi' ngaso sonke isikhathi.
- Unezaba eziningi zokuthi kungani eziphatha ngendlela exakile, ngoba yena engaboni ukuthi unalezi zinkinga.

? Ngingabhekana kanjani nalezi zinkinga?

- Thola usizo kwi-occupational therapist noma kwisazi sokusebenza kwengqondo kanye nokuziphatha komuntu (cela umtholampilo wangakini ukuthi ukuthumele kwisazi esifanelekile).
- Kumele umkhumbuze njalo usuku nesikhathi umuntu onesifo sohlangothi. Beka iwashi nekhanda endlini ahleli kuyo, futhi kumele umkhombise lokhu njalo.
- Kumele ulandele inqubo efanayo yokwenza izinto nsukuzonke, njengokuthi adle, anakekele umzimba (ukugeza, ukuxubha amaziyo, ukukama izinwele) futhi aphumule ngesikhathi esifanayo, ngendlela efanayo nsukuzonke.

- Kumele uqale kusasele isikhathi eside ukumchazela izinguquko okungenzeka zibe khona kwinqubo ejwayelekile okwenziwa ngayo izinto nsukuzonke, isibonelo uma kuzodingela ukuthi uhambe uye esitolo noma emtholampilo. Le ncazelo kumele uyiphindaphinde njalo.
- Kumele ugweme ukumvumela ukuthi aziphathe ngendlela ethile ngolunye usuku bese uma ephinda into efanayo ngolunye usuku ungamvumeli ukuthi ayenze. Thatha isinqumo sokuthi yini oyibona njengendlela yokuziphatha eyamukelekile, bese uqinisekisa ukuthi uziphatha ngaleyo ndlela ngaso sonke isikhathi.
- Ungamvumeli ukuthi akulawule ngokusebenzisa indlela yokuziphatha engamukelekile. Isibonelo, ungamvumeli ukuthi athole noma yini ayifunayo ngoba nje ememeza.
- Kumele ube nemithetho ecacile ephathelene nokuziphatha ngendlela engamukelekile. Isibonelo, kumele uthi: 'Ungamemezi. Ngeke ngikuphendule uma umemeza.'
- Ungahleki uma eziphatha ngendlela exakile noma engamukelekile, njengokusebenzisa inhlamba, noma ngabe lokho kuyahlekisa.
- Mncome uma eziphatha kahle noma eziphatha ngendlela eyamukelekile. Isibonelo, kumele uthi: 'Ngiyathanda ukukusiza uma ukhombisa ukubonga nokuluthokozela usizo lwami.'
- Kumele umvumele ukuthi alekelele uma kuthathwa izinqumo.
- Kumele umyeke azenzele ngokwakhe izinto eziningi, kodwa kumele ube seduzane ngokwanele ukuze uqinisekise ukuthi uphephile, isibonelo uma esegunjini lokugezela noma ekhishini.
- Kuyinto ejwayelekile ukuthi bateteme noma batefe abantu abahlaselwe yisifo sohlangothi. Uma engakhaliswa yingcindezi yomphefumulo, zama ukuthi umenze akhohlwe yinto emkhalisayo njengokuthi umcele ukuthi abale aze afinyelele eshumini noma aphefumule, adonse umoya kakhulu. Ungakhombisi ukuba nozwelo ngokweqile ngoba lokho kuzomenza akhale kakhulu kunakuqala.

4. Indlela okumele ahlale/alale ngayo umuntu ohlaselwe yisifo sohlangothi

Uma umuntu ohlaselwe yisifo sohlangothi ehlala noma elala ngendlela efanelekile, lokho kungamenza alulame ngokushesha futhi asebenze kangcono. Ukuhlala noma ukulala ngendlela engafanelekile kungazibhebhethekisa izinkinga ezinjengokuqina nokugongobala kwe-misipha nezicubu zomzimba, kanye nezinhlungu emzimbeni futhi kungenza alushaye indiva uhlangothi lomzimba wakhe olubuthakathaka.

? Kumele alale kanjani embhedeni umuntu onesifo sohlangothi?

Imihlahlandlela ejwayelekile:

- Sebenzisa umatilasi oqinile (ongekho ntofontofo kakhulu futhi ongaqinile kakhulu), noma ke ufake into eyipulangwe njengesicabha esidala ngaphansi kukamatilasi.
- Ubonda lwendlu kumele ngaso sonke lube ngasohlangothini lomzimba wakhe olunamandla.
- Kumele ngenkathi ecambalele uhlangothi lomzimba wakhe olubuthakathaka lubheke ngasemnyango, ngakumabonakude, ngasesihlalweni sezivakashi, njalo njalo. Lokhu kuzomlekelela ukuthi alukhohlwe noma angalunaki uhlangothi lomzimba wakhe olubuthakathaka.
- Kumele achithe isikhathi esincane kakhulu embhedeni.
- Uma esembhedeni, kumele alale ngohlangothi esikhundleni sokulala ngomhlane.
- Umuntu ohlaselwe yisifo sohlangothi ongakwazi nakancane ukunyakaza kumele umphendule embhedeni njalo emva kwamahora amabili noma amathathu ukuze uvimbele ukuqina kwe-misipha nezicubu zomzimba kanye nezilonda ezibangelwa wukulala embhedeni ngokweqile.

Indlela yokulala ngezinhlangothi zombili

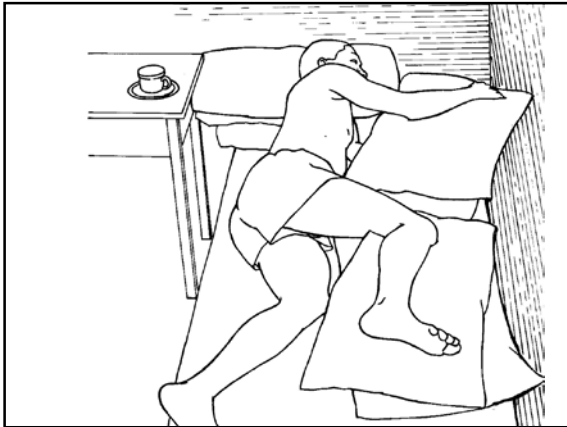

...kulala ngohlangothi olunamandla.



...kulala ngohlangothi olubuthakathaka.

1. Qinisekisa ukuthi indololwane yakhe ayisondeli emzimbeni futhi ulele ngokunethezeka.
2. Kumele isandla sakhe esibuthakathaka sihlale sivulekile, futhi ungabeki lutho kusona.
3. Uma elele ngohlangothi olunamandla, beka into ethile ngaphansi kwendololwane nesandla esibuthakathaka ngenhloso yokusekela lokhu.
4. Uma elele ngohlangothi olubuthakathaka, ungamvumeli ukuthi alale ngejoyinti lehlombe. Beka ihlombe phambi kwesifuba, hhayi ngaphansi komzimba.
5. Gobisa idolo elingaphezulu.
6. Beka imicamelo noma ingubo yokulala egoqiwe ngaphansi kwedolo nonyawo olungaphezulu ukuze lokhu kusekeleke ngokuphelele.
7. Uma umbhede wakhe kungewona umbhede obanzi ngokwanele, kumele isandla nengalo ebuthakathaka ukubeke phezu kwebhokisi lekhalibhodi noma etafuleni elibekwe eduze kombhede. Qinisekisa ukuthi ibhokisi noma itafula kulingana nombhede ngokuphakama - akumele kube phansi kakhulu noma phezulu khakhulu.

Indlela yokulala ngomhlane

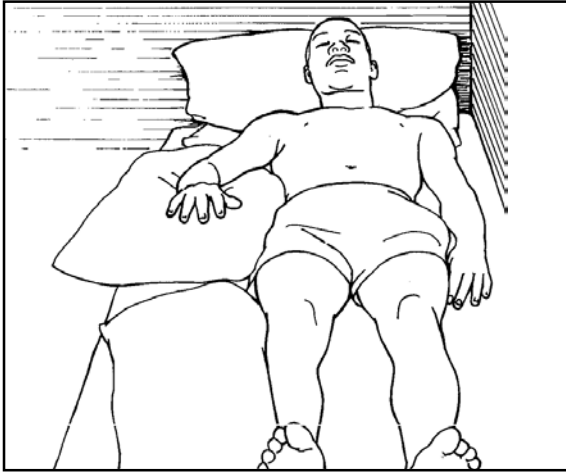

1. Umuntu ohlaselwe yisifo sohlangothi kumele alale ngomhlane isikhashana esifushane kuphela.
2. Ngasohlangothini olubuthakathaka beka itafudlana elincane.

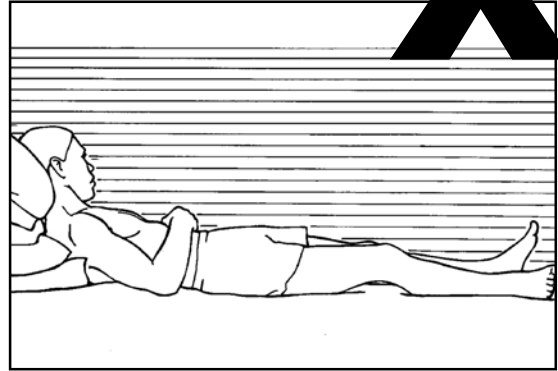

Ungamvumeli alale phezu kwenqwaba yemicamelo, ebekwe ngaphansi komhlane wakhe. Lokho kungenza abe nalokhu okulandelayo:

- Izilonda ezibangelwa wukulala ngokweqile
- Izinkinga eziphathelele nokuphefumula
- Izinkinga eziphathelele nokugwinya
- Ukuqina kakhulu kwengalo nomlenze
- Umgogodla ogobile kanye nesimo sekhandla esigobele phambili

Indlela yokuhlala phezu kombhede (kuphela uma umuntu engakwazi ukusuka embhedeni)

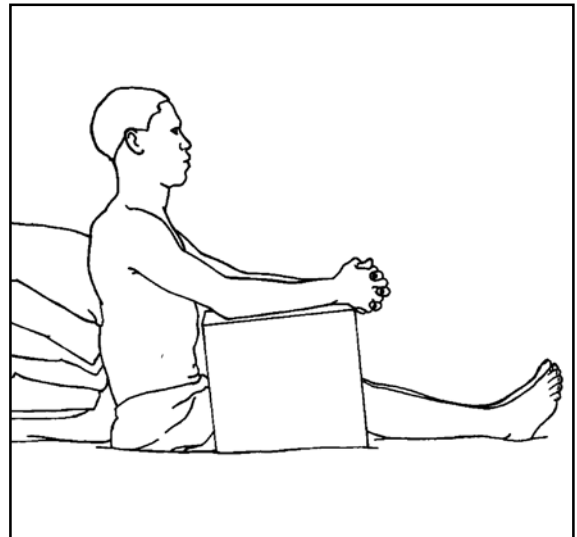
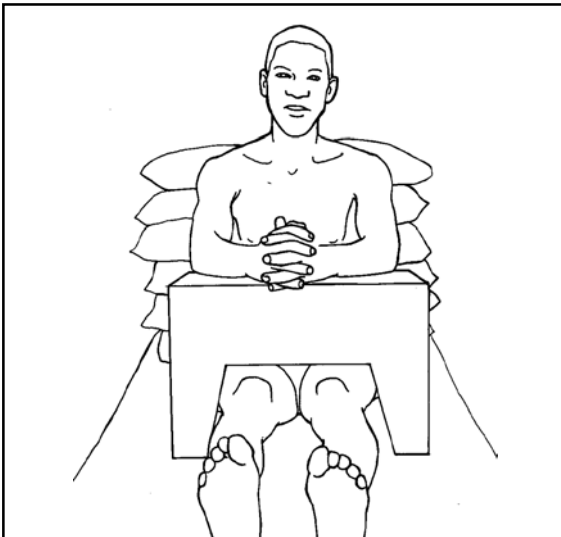

1. Mvumele ahlale aqonde futhi anabe phezu kombhede. Uma ubeka umcamelo ngaphansi kwamadolo lokho kuzomenza anethezeke kangcono.
2. Umhlane wakhe kumele uncike obondeni noma kwi-headboard. Uma engakwazi ukusondela enhla kombhede beka isihlalo noma isitulo phakathi kwakhe ne-headboard.
3. Beka imicamelo noma ingubo yokulala egoqiwe emva komhlane wakhe ukuze asekeleke kahle.
4. Sebenzisa ibhokisi (bheka umfanekiso ongezansi) ukwakha itafudlana elibekwa emathangeni, lapho ezobeka khona izingalo zakhe.
5. Kumele ahlale ngale ndlela kuphela uma engakwazi ukusuka embhedeni.

Indlela yokwakha itafudlana elibekwa emathangeni ngebhokisi lekhalibhodi

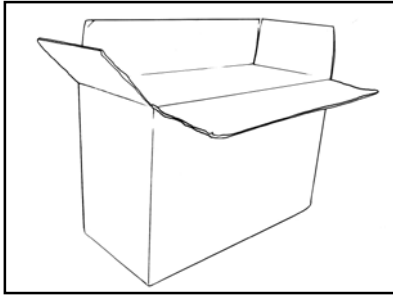

1. Sebenzisa ibhokisi eliqinile futhi elibanzi ngokwanele elizongena kalula phezu kwamathanga womabili.

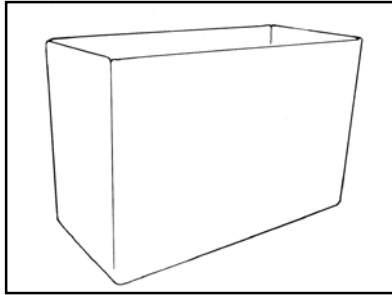

2. Sika amachopho ebhokisi noma uwanamathisele kwingxenye engaphakathi kwebhokisi ukuze uqinise izinhlangothi zebhokisi.

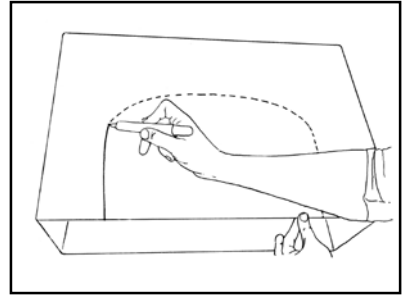

3. Dweba isiyingi esiwuhhafu (arch) ezinhlangothini zombili zebhokisi. Inhliso yalokhu ukwenza imbobo ezovumela izinyawo zingene ngaphansi kwetafula, kumele uqinisekise ukuthi le mbombo inkulu ngokwanele.

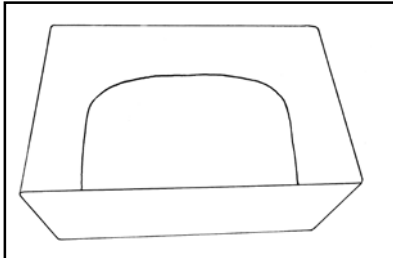

4. Isiyingi esiwuhhafu kumele sibukeke ngale ndlela uma usuqedile ukusakha.

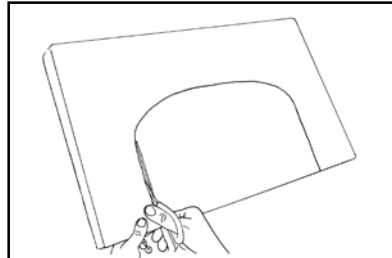

5. Manje sika isiyingi esiwuhhafu kolayini obadwebile ukuze kuvuleke imbobo.

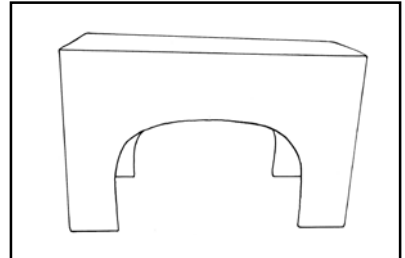

6. Manje selikulungele ukusetshenziswa itafudlala elibekwa emathangeni.



Kumele ahlale kanjani umuntu onesifo sohlangothi?

Indlela yokuhlala esihlalweni esijwayelekile noma esihlalweni esihamba ngamasondo

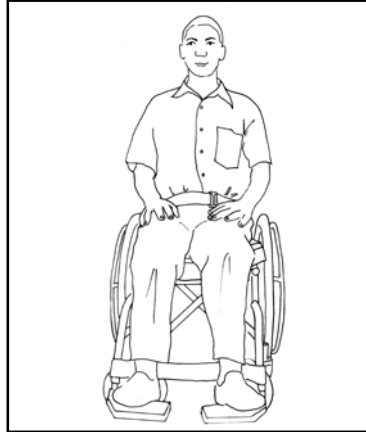
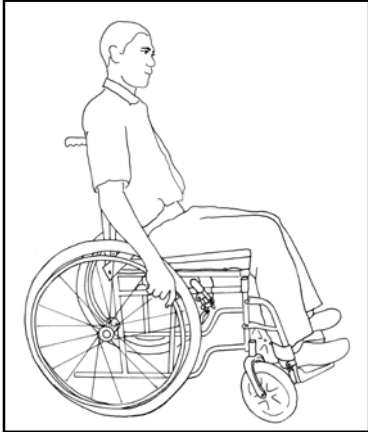

Esihlalweni esinamasondo kumele ngaso sonke isikhathi usebenzise ikhushini noma umcamelo wesihlalo esinamasondo.

Imihlahlandlela ejwayelekile:

- Isihlalo kumele kube ngesincane ngokwanele ukuze angene khaxa kusona.
- Kumele kube yisihlalo esiqinile. Sebenzisa isihlalo esinendawo yokuqhiyama eqinile futhi kumele sibe nendawo yokuhlala eqinile esikhundleni sendawo yokuhlala entofontofu.
- Kumele ahlale aqonde, umhlane wakhe uncike kwindawo yokuqhiyama.
- Izingqo zakhe kumele zincike ngasemuva kwesihlalo. Uma ezizwa engabhalansile noma enganethezekile kahle ngenkathi encike emuva, beka umcamelo omncane ngasemuva kwendawo yokuhlala.
- Izinyawo zakhe kumele zihlale phansi noma phezu kwendawo yokubeka izinyawo ukuze asekeleke kahle. Uma izinyawo zakhe zingafinyeleli phansi, zisekele ngebhulokhi lokhuni, noma isitaki samaphephandaba noma okhalibhodi ababoshwe ndawonye.

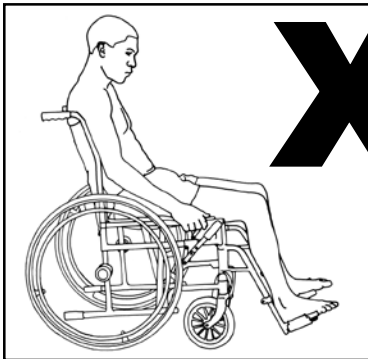

Uma umuntu ohlaselwe yisifo sohlangothi engahlali ngendlela efanelekile, lokho kungabangela:

- Ukuphatheka kabi emzimbeni kanye nezinhlungu
- Ukuqina nokugongobala komlenze noma ingalo ebuthakathaka
- Ukuvuvukala kwesandla noma kwengalo
- Uzoshelela, aputshuke esihlalweni



Asiza kanjani amabhande ukuze umuntu angasheleli futhi angaputshuki esihlalweni?

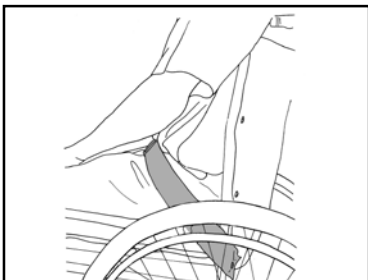

Mbophe ngebhande ulivundlise enqulwini yakhe, futhi ibhande kumele lihambe ngemuva okhalweni lwakhe liphume emakhoneni esihlalo.

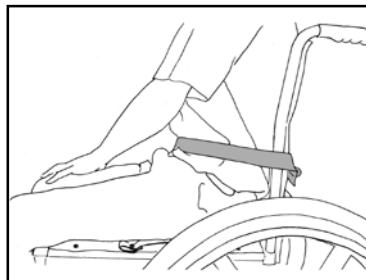

Ungambophi ngebhande esiswini noma esifubeni.

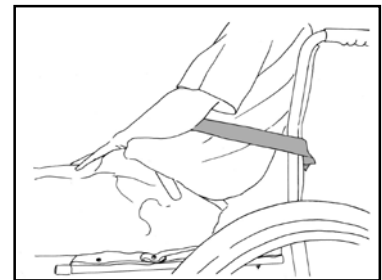

Kungenzeka ashelele noma aputshuke uma umbophe esiswini noma esifubeni.



Liboshelwa kanjani esihlalweni ibhande eliboshwa emathangeni?

Mayelana nesihlalo esihamba ngamasondo

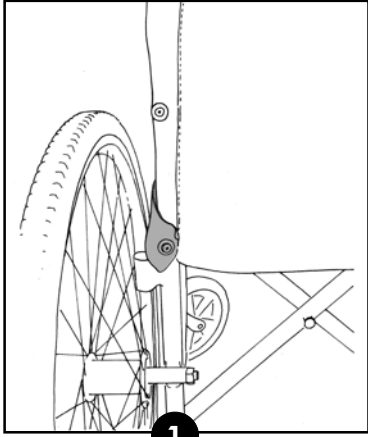

Bophela ibhande ohlakeni lwesitulo esihamba ngamasondo ngokusebenzisa isikulufu esisezansi sendawo yokuqhiyama yesihlalo esihamba ngamasondo noma isikulufu esingemuva sendawo yokuhlala.

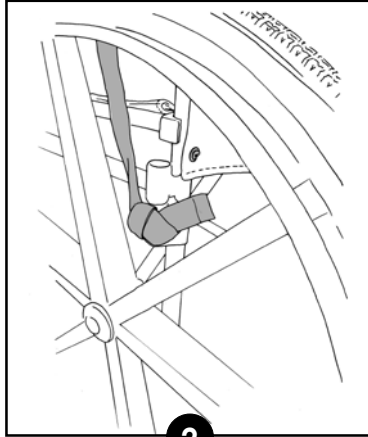

Ibhande ungalibophela kwingxenywe ebheke phezulu yohlaka lwesihlalo esihamba ngamasondo, ngaphansana nje kancane kwengxenywe engemuva yendawo yokuhlala.

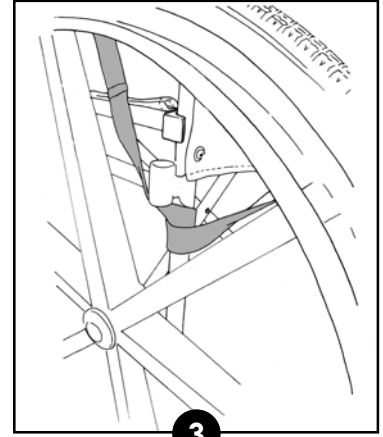

Uma usebenzisa ibhande elide elilodwa elibopha ingxenywe yomuntu engaphambili, kumele uligaxe futhi ulihlele kwingxenywe yesihlalo esinamasondo ebheke phezulu ohlangothi olulodwa, ngaphansi kwengxenywe engemuva yendawo yokuhlala.

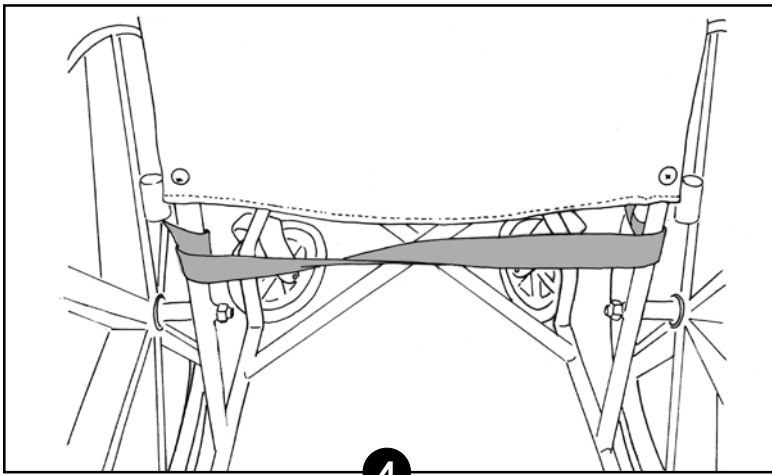

Bese ulihambisa ngemuva kwesihlalo liye kulolu olunye uhlangothi lohlaka lwesihlalo esinamasondo, ngaphansi kwengxenywe engemuva yendawo yokuhlala.

Mayelana nesihlalo esijwayelekile

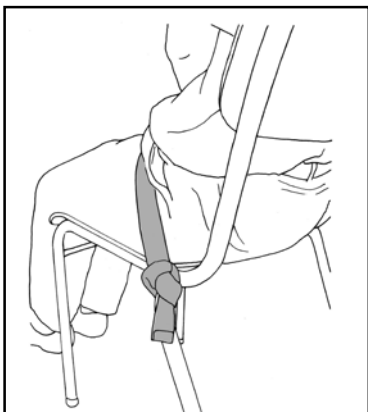

Ibhande kumele ulibophele emilenzeni yangemuva yesihlalo, ngaphansana kancane nje kwendawo yokuhlala.



Ngingazisekela kanjani izingalo nezandla zakhe?



Makazibeke phezu kwetafula.

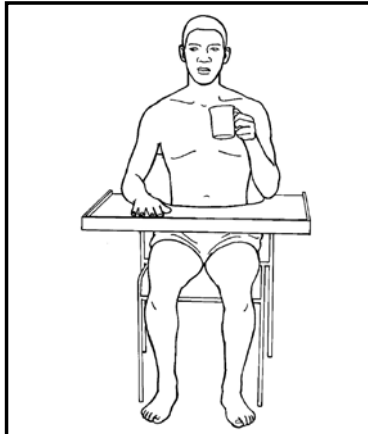

Makazibeke phezu kwethileyi elibekwa emathangeni.



Ungalokothi ufake ingalo kwisilengiso esifakwa emqaleni sokulengisa ingalo.

Imihlahlandlela ejwayelekile:

- Kumele ngaso sonke isikhathi uqinisekise ukuthi wonke umkhono, kubandakanya indololwane nesandla, ubekwe phezu kwetafula noma phezu kwengxenywe yesihlalo okubekwa kuyona izingalo noma etafuleni eliyithileyi.
- Isandla kumele sihlale sivulekile futhi kumele intende yesandla ibeke phansi, ilale mba phezu kwetafula, noma phezu kwengxenywe yesihlalo okubekwa kuyona izingalo noma ethileyini.
- Ungalokothi usebenzise imicamelo phezu kwamathanga ukusekela ingalo ebuthakathaka ngenkathi umuntu ehleli. Lokhu akumnikezi ukusekeleka okwanele, futhi kungenzeka isandla sivuvukale noma liklunyuke ijoyinti lehlombe. (Ukunakekelwa kwehlombe kuchazwe kabanzi kwiSahluko 6.)

Isibonelo setafula eliyithileyi

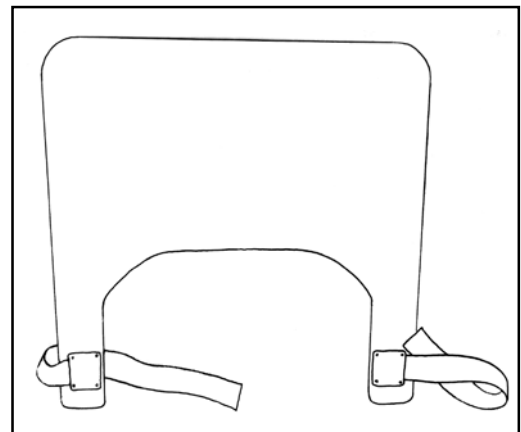
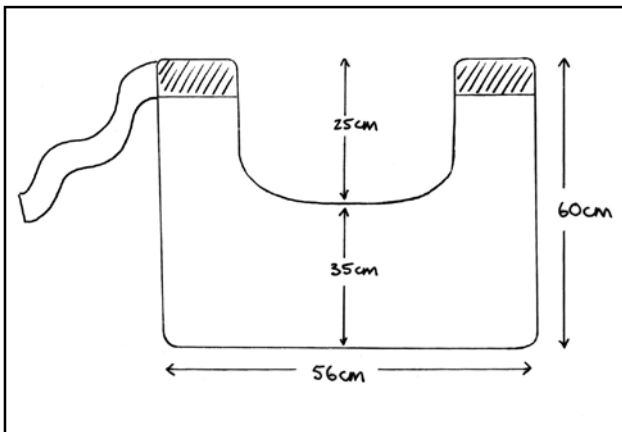

Ungalakha itafula eliyithileyi ngokusebenzisa uqawembe olunogqinsi futhi oluqinile noma usebenzise ipulangwe elingelona ugqinsi. Kuhlala ngosani phepha ingaphezulu letafula eliyithileyi kanye nonqenqema lwalo. Ingaphezulu lethileyi ungalipenda noma uligcobe ngovanishi ukuze lingalinyazwa ngamanzi futhi ukuze kube lula ukulisula nokulihlanza. Usayizi wetafula kumele uwenze ulingane nobukhulu nobude besihlalo kanye nobomuntu onesifo sohlangothi.

5. Ukudla, ukugwinya kanye nokunakekelwa kwamazinyo/komlomo



Ngingamlekelela kanjani umuntu onesifo sohlangothi ukuthi adle?

Umuntu onesifo sohlangothi kumele enze lokhu okulandelayo:

- Kumele ahlale ngesinqe ngaso sonke isikhathi ngenkathi edla.
- Kumele ahlale aqonde.
- Kumele agebise ikhanda kancane liye phambili.
- Kumele amehlo awaqondise ekudleni akudlayo.
- Kumele abeke izingalo etafuleni.
- Kumele abeke izinyawo kwindawo yokubeka izinyawo esi-hlalweni esinamasondo noma azibeke phansi.
- **Kumele adle kancane kancane futhi aphuze kancane kancane.**
- Kumele ukudla akuhlafunayo akuhambise kwingxenye emamaphakathi nolimu ngaphambi kokuthi akugwinye.
- Kumele aphuze engilazini egcwele noma asebenzise umbhobho wokuphuza ngenhloso yokuvimbela ukuthi ikhanda lingaqekuzi liye emuva.
- Kumele aqhubeke ahlale ngesinqe okungenani isikhathi esiyimizuzu engama 20–30 emva kokudla ukuze kugayeke.

Njengomnakekeli kumele wenze lokhu okulandelayo:

1. Kumele uhlale phambi komuntu onesifo sohlangothi, noma ume ngezinyawo eduze kwakhe.
2. Ngenkathi ume ngezinyawo, beka unyawo lwakho entweni enjengebhulokhi lokhuni noma isigqiki esifushane, ngenhloso yokusekela umzimba wakho.
3. Kumele ngasosonke isikhathi uhlale uqondile umhlane wakho; ungawugobisi.
4. Sebenzisa ingalo yakho eseduzane nomuntu onesifo sohlangothi ukusekela ikhanda lakhe.
5. Mfunze ukudla, phakathi kwamazinyo, ngasohlangothini lomlomo wakhe olunamandla.
6. Kumele umfunze ukudla okuwuketshezi olushubile kanye nokudla okulula. Iyogathi, ukhastadi kanye nesobho elishubile kugwinyeka kalula.



Uma umuntu onesifo sohlangothi ekhwehlela njalo noma ebindeka ngenkathi edla, cela ukubonana ne-speech therapist (umelaphi wezinkinga eziphathelene nokukhuluma).

Umelaphi angahlola ukuthi umuntu onesifo sohlangothi uyakwazi yini ukugwinya ukudla kanye nokuphuza iziphuzo ngokuphepha, emva kwalokho anikeze iseluleko esifanelekile sokwenza ngcono indlela umuntu agwinya ngayo ukudla.

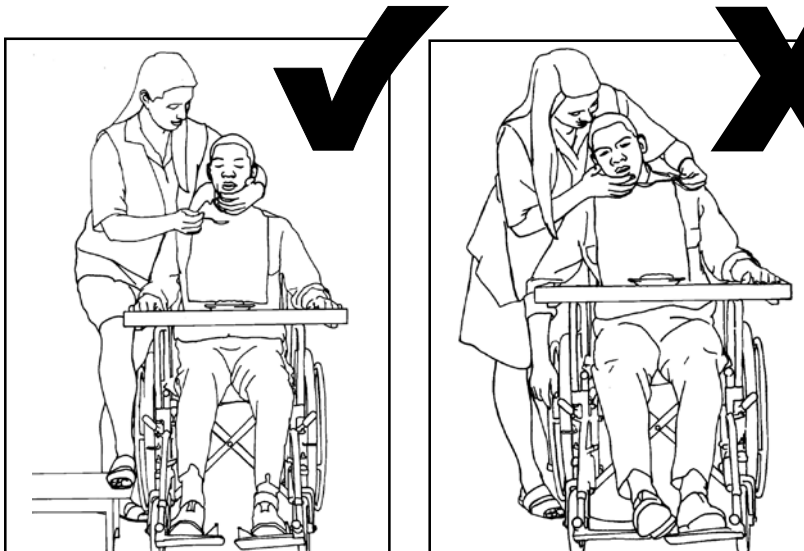

- Ungalivumeli ikhanda lomuntu onesifo sohlangothi ukuthi linqekuze liye ngapha nangapha noma liye emuva.
- Ungayivumeli ingalo ukuthi ilenge noma isuke etafuleni, noma isuke endaweni yokubeka izandla noma ethileyini elibekwa emathangeni.
- Ungazivumeli izinyawo ukuthi zishelele futhi zisuke endaweni okubekwa kuyona izinyawo esi-hlalweni esinamasondo.



- Akufanele ukuthi kuze kudingeke ukuthi umuntu onesifo sohlangothi akhuphule ikhanda lakhe noma alihambise phambili ukuze afinyelele ekudleni. Lokhu kwenza ukuthi kube nzima ukugwinya ukudla.
- Kumele isipuni usibeke phambi kohlomo wakhe.
- Hambisa isipuni emlonyeni wakhe. Kumele umfunze ngendlela yokuthi kungabi khona isidingo sokuthi ahambise ikhanda lakhe phambili ukuze afinyelele esipunini.

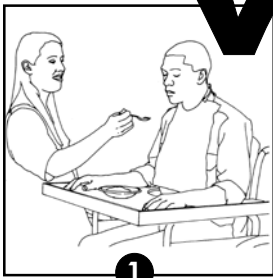

1

Beka isipuni phambi kolimu lwakhe.



2

Uma luphumela ngaphandle ulimu lwakhe, kumele ulucindezele kancane ngesipuni luye phansi.

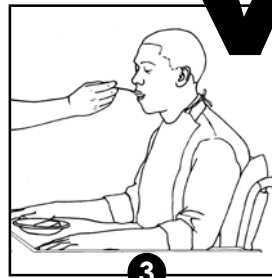

3

Qinisekisa ukuthi izindebe zakhe zisivalele ngaphakathi kohlomo isipuni.

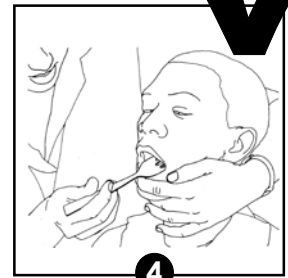

4

Beka ukudla phakathi kwamazinyo ngasohlangothini lwakhe olunamandla.



Ngimlekelela kanjani umuntu ukuthi aphuze?



- Beka iminwe yakho esihlathini sakhe, esilevini kanye nasemhlathini wakhe ongaphansi ukuze umlekelele ukuthi akwazi ukuvula izindebe zakhe noma umlomo wakhe. Kumele uqaphele ukuthi awulitshekiseli emuva ikhanda lakhe.

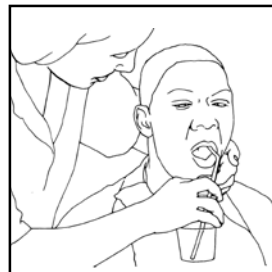

- Uma usebenzisa umbhobho wokuphuza, kumele ngaso sonke isikhathi uwubeke ngasohlangothini lomlomo olunamandla, uncike esihlathini sakhe.



- Uma engakwazi ukuphuza enkomishini noma ukuphuza ngombhobho, sebenzisa isifutho somjovo (syringe) esingenayo inaliti ukufaka iziphuzo noma ukudla okuwuketshezi emlonyeni wakhe.
- Kumele isifutho somjovo usibeke ngasohlangothini lomlomo olunamandla, usincikise esihlathini sakhe. Faka ukudla okuwuketshezi ngesifutho somjovo kuqonde ngasesihlathini sakhe.



Ngimsiza kanjani umuntu okuthola kunzima ukubeka ukudla emfolokweni/esipunini ngesandla esisodwa?

Sebenzisa ipuleti elijulile noma into ebekwa ngasonqenqemeni lwepuleti evimbela ukudla kungaweli phansi (uhlobo oluthile 'lwesivimbo') ukuze ukudla kungasheleli epulefini bese kuwela phansi

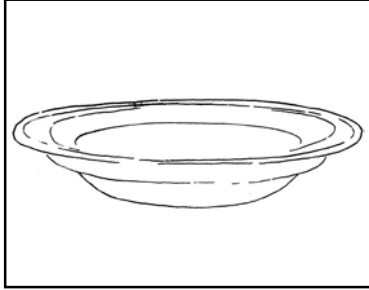

Ipuleti elijulile.



Ipuleti elinesivimbo esithengwa esitolo sokuvimbela ukuthi ukudla kungaweli phansi.



Isivimbo sokuvimbela ukuthi ukudla kungaweli phansi esakhiwe ekhaya.

Indlela yokwakha isivimbo sokuvimbela ukudla kungaweli phansi

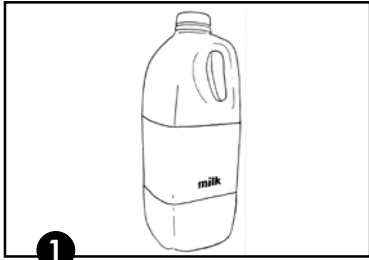

1. Thatha ibhodlela lepulastiki lobisi noma lojusi eliyilitha elilodwa noma amabili.

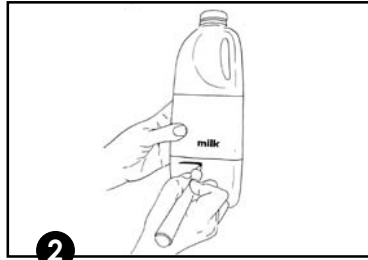

2. Dweba umugqa ovundlayo ebangeni elingamasenti-mitha ama-5 ukusuka esinqeni sebhodlela (ozungeza isinqe sebhodlela).

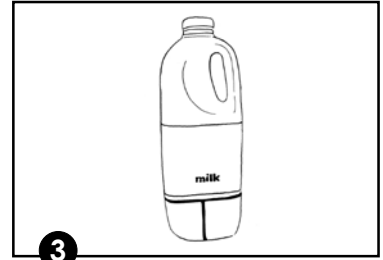

3. Manje dweba umugqa owehlayo unqamule phezu komugqa ovundlayo, futhi wehle njalo uze uyongamula esinqeni sebhodlela.

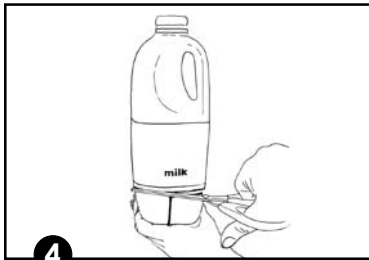

4. Sika phezu komugqa ovundlayo ukuze unqamule noma ukhiphe isinqe sebhodlela.

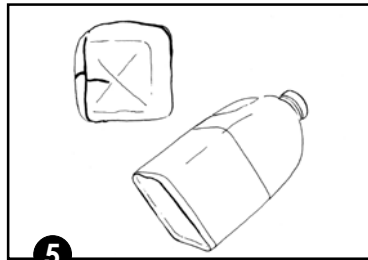

5. Sikhiphe isinqe sebhodlela.

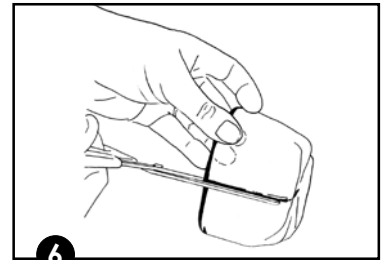

6. Sika isinqe sebhodlela emgqeni onqamula maphakathi nebhodlela ukuze libe yizingcezu ezimbili.

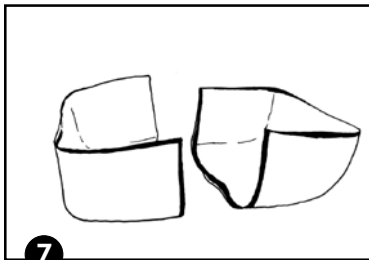

7. Manje usunezingcezu zesinqe sebhodlela ezimbili ezahlukene.

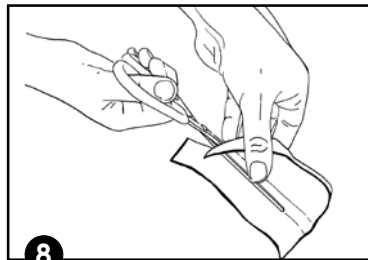

8. Sebenzisa ucezu olulodwa kulezi ezimbili. Sika uhlangothi olulodwa lube nobubanzi obulingana nonqenqema lwepuleti.

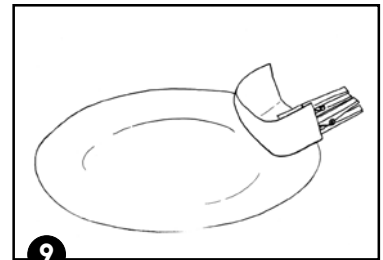

9. Namathisela lolu cezu onqenqemeni lwepuleti usebenzisa amaphekisi okuneka izingubo.

Indlela yokwenza uqwembe olungasetshenziswa ngumuntu okwazi ukusebenzisa ingalo eyodwa kuphela, ngenkathi egcobisa isinkwa noma ecwecwa izithelo



Ukugcobisa ngesandla esisodwa.



Ukucwecwa ngesandla esisodwa.

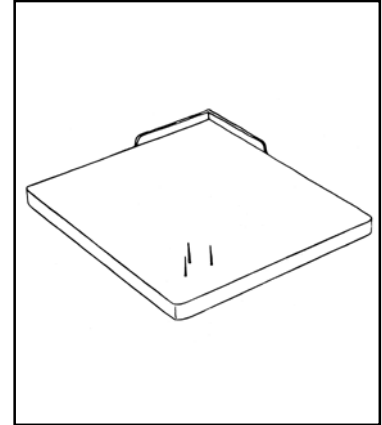

Uqwembe olungasetshenziselwa kokubili ukugcobisa kanye nokucwecwa ngumuntu okwazi ukusebenzisa isandla esisodwa kuphela.

Uzodinga lokhu:

- Isitokwana sokhuni, njengoqwembe oludala lokuqobela isinkwa, 15 cm x 15 cm
- Izipikili ezintathu ezingamasentimitha ayisishiya-galombili ubude
- Izipikili ezine ezimfishane
- Imicu emibili yensimbi noma kapulastiki oqinile, ongamasentimitha ayisithupha ubude futhi ophakeme ngesentimitha elilodwa ukusuka okhunini

Indlela yokwenza:

1. Qonqothela izipikili ezintathu ezinde ekhomeni lokhuni ukuze wenze unxantathu noma isikwele (bheka isithombe).
2. Sebenzisa izipikili ezimfishane ukunamathisela imicu yensimbi noma kapulastiki ezinhlangothini zombili zekhona eliqondene nezipikili. Imicu kumele ibe wugabagaba oluyisentimitha elilodwa ngaphezu koqwembe.

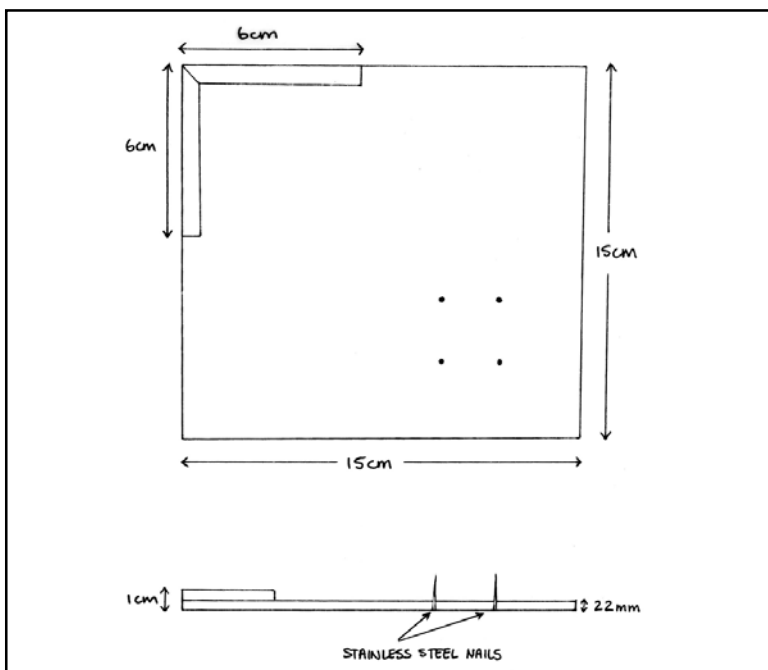

Isilinganiso sobude nobubanzi boqwembe lokuqobela isinkwa noma ecwecwa kanye neminingwane ephathelene nendlela yokwakha lezi zingqwembe

Indlela yokwakha isibambo esikhudlwana uma umuntu ekuthola kunzima ukubamba isibambo esincane

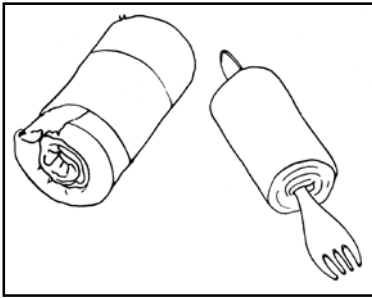

Uzodinga lokhu:

- Isipuni noma imfoloko
- Isiponji esiwugqinsi esinobude obungu-6 cm x 10 cm (lokhu kuzoya ngokuthi side kangakanani isipuni, nokuthi kumele sibe wugqinsi olungakanani isibambo)
- Isinamathelisi sohlobo lwe-Elastoplast/duct tape

Indlela yokwenza:

1. Goqa isibambo sesipuni noma semfoloko ngesiponji ukuze wenze isibambo sibe sikhudlwana.
2. Sibophe ngesinamathelisi sohlobo lwe-Elastoplast/duct tape.



Ngingamlekelela kanjani umuntu ukuthi ageze amazinyo akhe?



1. Makahlale phambi kwesibuko.
2. Makahlale aqonde.
3. Kumele ikhanda lakhe lihlale liqondile.
4. Isandla esibuthakathaka kumele usibeke phezu kwetafula noma konqenqema lukabheseni.
5. Yima ngezinyawo emva kwakhe bese uqondisa amehlo akho esibukweni.



Ungalitshekiseli emuva noma emaceleni ikhanda lakhe.

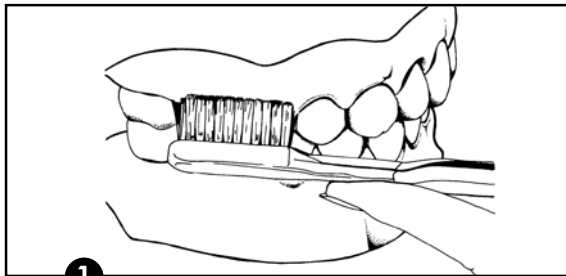

1
Bamba isixubho kwi-engela engama-45° (kumele sitsheke kancane) yezinsini namazinyo akhe.

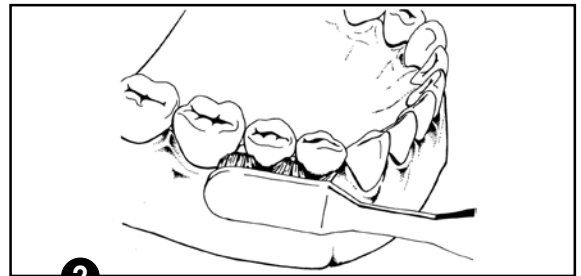

2
Xubha amazinyo akhe, wenze iziyingi ezincane.

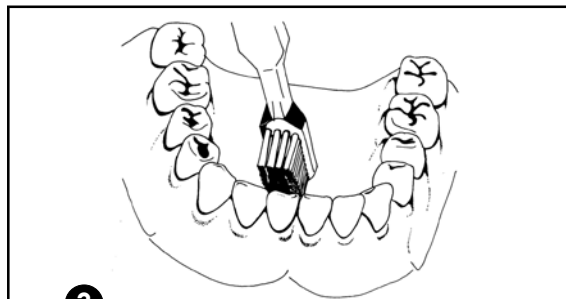

3
Xubha ingaphakathi kanye nengaphandle lamazinyo akhe.

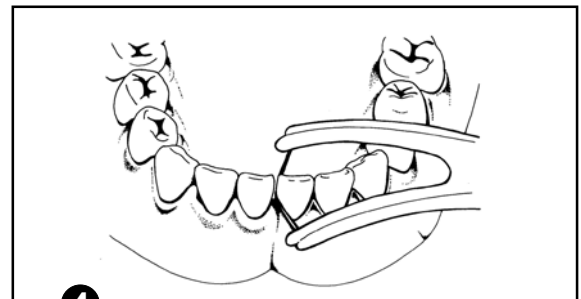

4
Uma uvungula phakathi kwamazinyo kumele usebenzise isibambo sentanjana yokuvungula amazinyo (floss holder). Bheka isibonelo sesimbambo sentanjana yokuvungula amazinyo ngezansi.



Ngingamlekelela kanjani umuntu ukuthi akwazi ukubamba isixubho uma isandla sakhe sibuthakathaka kakhulu?

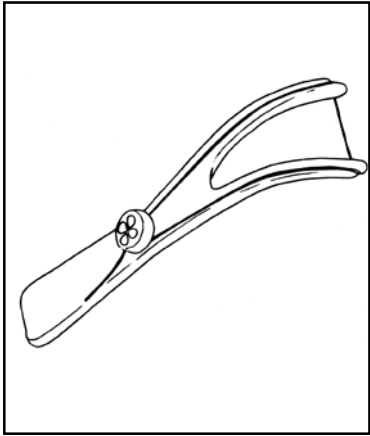

Isibonelo sentanjana yesibambo sokuvungula amazinyo.

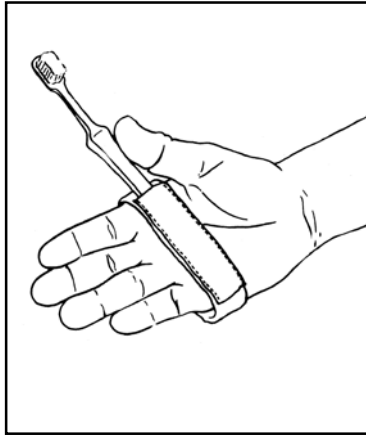

Isibonelo sesibambo sesixubho.

Isibambo sesixubho esilula singenziwa ngendwangu yokukhava osofa eqinile futhi enganwebeki noma olunye uhlobo lwendwangu eqinile. Yakha ibhande elinanyatheliswa esandleni nge-Velcro (isinamathe-lisi sendwangu). Thunga ikhukhu kwingxenye yendwangu esentendeni yesandla, okungangena kulona isixubho. Ikhukhu kumele libe nembobo encane ngokwanele ezokwazi ubamba isixubho singanyakazi.

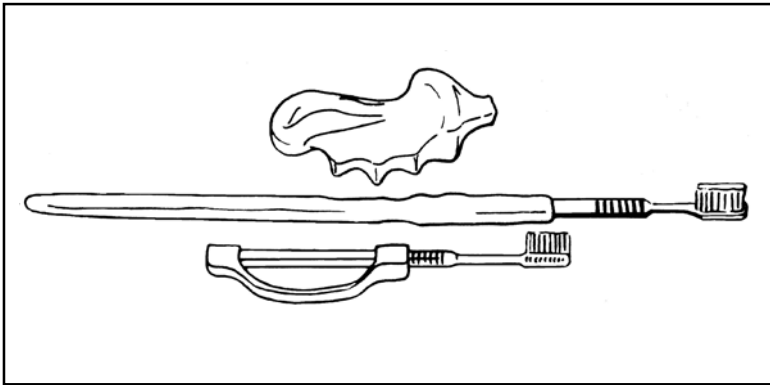

Ezinye izinto zokwenza ngcono indlela umuntu abamba ngayo isixubho zibandakanya lokhu okulandelayo:

- Sebenzisa isibambo esikhulu. Isibambo esikhulu ungazenzela sona ngokwakho ngokulandela indlela echazwe ngenhla, noma usithenge esitolo esithengisa izibambo zezixubho.

NOMA

- Usebenzise isibambo eside. Isibambo eside sisebenza kahle kumuntu okuthola kunzima ukuphakamisa isandla sakhe ngokwanele.

NOMA

- Uthenge isibambo sesixubho esitolo esithengisa izibambo zezixubho.

6. Ukunakekelwa kwamahlombe

Abantu abaningi abanesifo sohlangothi banenkinga yehlombe elibuhlungu kanye/noma eligongobele. Lokhu ungakugwema ngokuliphatha ngendlela efanelekile ihlombe.



Iyiphi indlela efanelekile yokunakekela ingalo ebuthakathaka noma ekhubazekile?

- Mbambe ngobunono ngasezimbanjeni ukumlekelela ukuthi aguquke, ahlale ngezinqe, asukume ame ngezinyawo, njalonjalo.
- Ungalokothi umdonse ngengalo.
- Ngaphambi kokugeza nokugqokisa ingalo ebuthakathaka, kumele ngaso sonke isikhathi uqinisekise ukuthi ikhululekile, akukho okuyibambile (isesimweni sokunyakaza kalula).

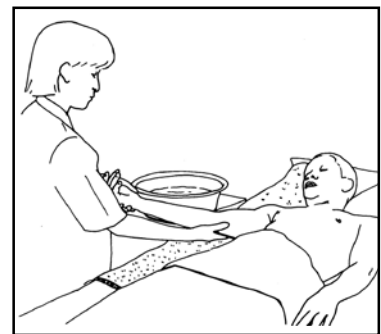
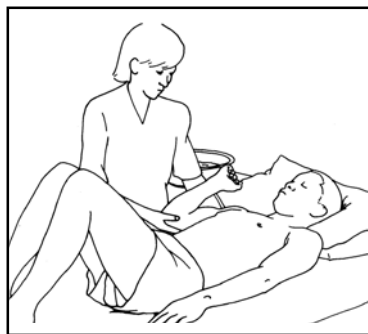

1. Gaxa isandla sakho esiphangeni sakhe sohlangothi olubuthakathaka.
2. Donsa isiphanga sakhe ngobunono siye eceleni bese siya phambili.
3. Kuphindaphinde lokhu izikhathi ezimbalwa lize likwazi ukunyakaza kalula ihlombe.
4. Gcina isiphanga sitshekele phambili.
5. Bamba ingalo ngaphezudlwana kancane nje kwendololwane bese uyiphendula ngokucophelela iye ngaphandle.
6. Kumele uyeke ukwenza lokhu uma ezwa ubuhlungu.
7. Ungalokothi ubambe isandla noma ingxenye yengalo engezansi kwendololwane ngoba lokhu kungabanga ubuhlungu noma umonakalo endololwaneni.
8. Uma ingalo seyinyakaza kalula, kumele uthathe ingxenye yengalo engehla kwendololwane ngobunono bese uyisa phambili isuke eduze komzimba.
9. Qondisa indololwane.
10. Manje phakamisa ijoyinti lehlombe ngokucophelela liye phezu futhi/noma liye eceleni ukuze ukwazi ukumgqokisa noma ukumgeza.



Ungalokothi umdonse ngengalo ebuthakathaka.



Yikuphi okumele ngikwenze mayelana nehlobo uma ngiphendula umuntu embhedeni?

- Ngaphambi kokuphendula umuntu embhedeni ukuze alale ngohlangothi lwakhe olubuthakathaka, kumele wenze ingalo yakhe inyakaze kalula ngokusebenzisa indlela echazwe ngenhla, bese uyidonsa iye phambili (phezu kwezimbambo).
- Sekela ingalo noma ihlombe kuleyo ndawo elime kuyona njengoba litshekele phambili. Ngenkathi ihlombe lime kulesi simo, umuntu angaguquka alale ngohlangothi olubuthakathaka.
- Ungamvumeli alale ngejoyinti lehlombe.



Ngingayisekela kanjani ingalo ngenkathi umuntu ehleli phansi?

- Sekela ihlombe eduze kohlangothi lomzimba ukuze ugcine ijoyinti lehlombe lisesimweni esiphephile. Into osekela ngayo kumele iphakame ngokwanele ukuze amahlombe ahlale eqondene.
- Uma into osekele ngayo iphansi kakhulu noma ikude kakhulu nomzimba, kungenzeka liklunyuke ithambo lengxenywe yengalo engaphezu kwendololwane futhi lokho kuzokwenza ukuthi linwebeke futhi livuleke ijoyinti lehlombe futhi lokho kuzodala izinhlungu.



Kungani kungafanele ukuthi ngisebenzise isilengiso sengalo?

Isilengiso sengalo esenzelwe ukuthi ingalo ilenge ngaphambili emzimbeni singabangela ukuthi ingalo igongobale kakhulu kunakuqala, izicubu ezizungeze ihlombe zizofinyela bese futhi kuba nzima ukuhambisa isandla siye ngasohlangothini lomzimba. Lokhu kuzobangela ukuthi izicubu zomzimba zikhonkobale uma umuntu ephakamisa ingalo ngenkathi egqoka noma egeza. Isilengiso sengalo singabangela futhi ukuthi isihlakala sigobe bese siyaqina noma sigongobale, futhi lokhu kungabangela ukuthi isandla sivuvukale.



Kungani kungafanele nakancane ukuthi nginikeze umuntu ibhola ukuze alifocofocoze ngesandla?

Ungalokothi umnikeze ibhola ukuze alifocofocoze ngesandla ngoba lokhu kuzokhulisa ukuqina nokugongobala kwesandla futhi kuzokwenza ukuthi kube lukhuni kakhulu ukuvula iminwe ukuze ageze futhi omise isandla ngethawula.



Iyiphi indlela elungile yokuvocavoca ihlombe?

Indlela elula yokuzivocavoca nenghloso yokugcina ihlombe, indololwane kanye nesihlakala kunyakaza kalula futhi ngaphandle kwezinhlungu

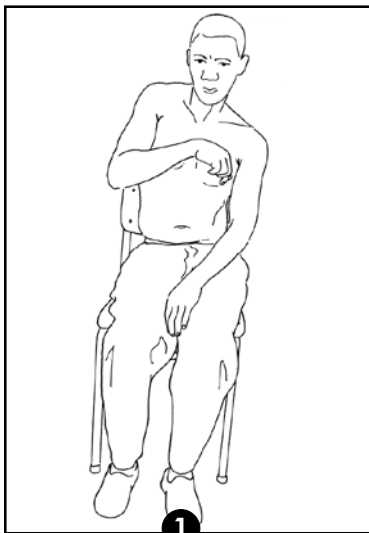

1

Sebenzisa isihlalo esiqinile esinengxenywe yokuqhiyama ekahle. Kumele umhlalise ngendlela yokuthi izinqe zakhe zithinte ingxenywe yesihlalo esemuva futhi izinyawo zakhe kumele zihlale mba phansi.

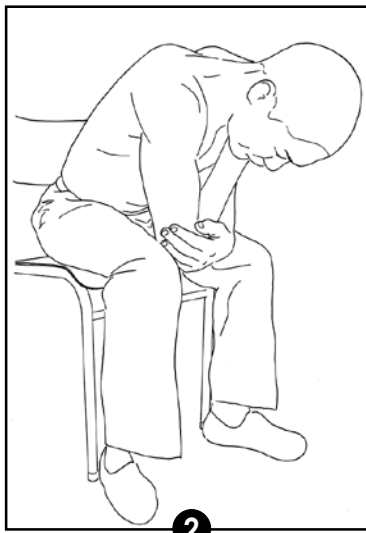

2

Manje umuntu kumele agobele phambili bese ehambisa indololwane ebuthakathaka ngobunono ize ifinyelele kwingaphakathi ledolo elibuthakathaka.

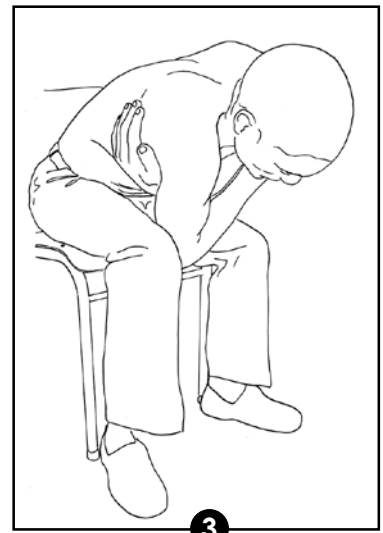

3

Umuntu kumele abambe isiphanga esibuthakathaka ngesandla sakhe esinamandla ngokuthi ahambise isandla ngaphansi kwekhwapha noma ngaphezu kwehlombe. Isingenhla somzimba wakhe kumele asidonse ngobunono sehle siye ngasedolweni elinamandla. Kuphinda-phinde lokhu kuze kufike isikhathi lapho isiphanga sesiye phambili ngokwanele.

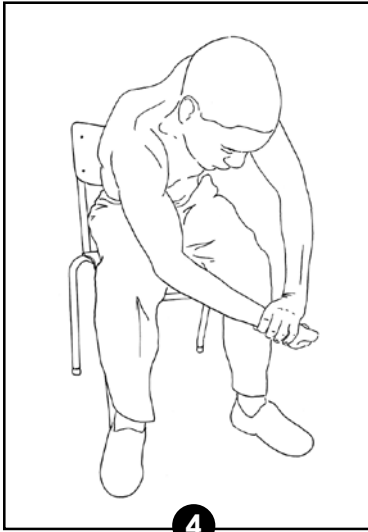

4

Umuntu kumele agcine umzimba wakhe ugobele phambili, abambe isandla sakhe esibuthakathaka esihlakaleni, bese eqala ukuqondisa indololwane yakhe ngobunono phezu kwedolo.



5

Lula ingalo kancane kancane phakathi kwamadolo ibheke ngasezinyaweni ize iqonde ngokwanele indololwane.

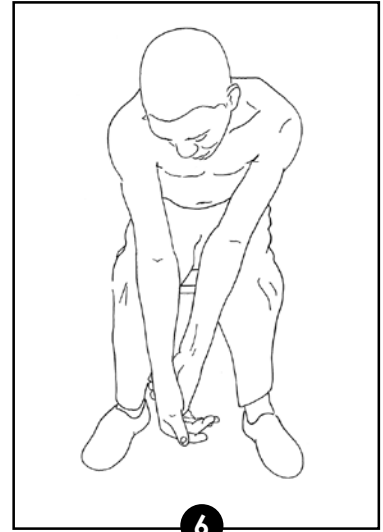

6

Uma kunokwenzeka, mvumele alule ingalo yakhe ize ifinyelele phansi.

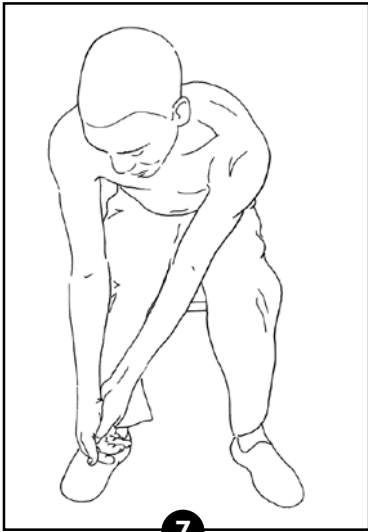

7

Manje mvumele ehlise izingalo zakhe ziye eceleni zize zifinyelele ezinhlangothini zombili zedolo elibuthakathaka. Izandla kumele zibe seduzane kakhulu konyawo.

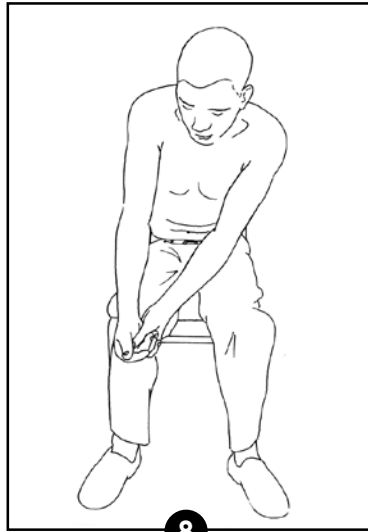

8

Khuphula izandla kancane kancane ziye esithweni somlenze obuthakathaka.

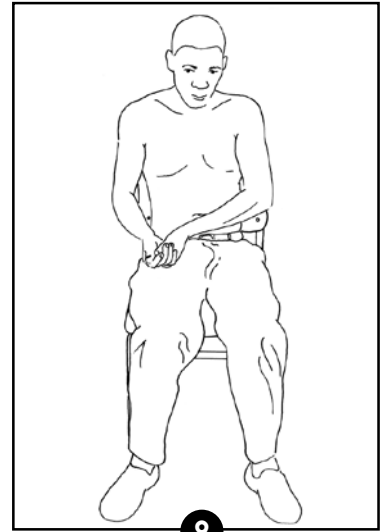

9

Qhubeka nokukhuphula izandla zize zifinyelele ethangeni elibuthakathaka.

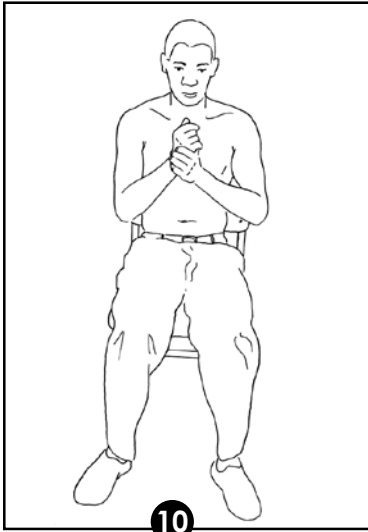

10

Letha izandla okhalweni bese uzikhuphula zize zifike esifubeni.

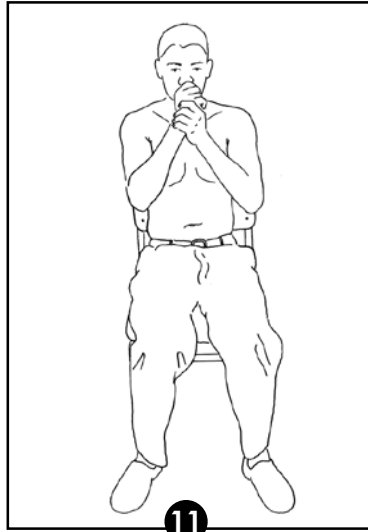

11

Umuntu kumele aqhubeke nokukhuphula izandla zize zithinte ikhala. Kodwa kumele aqhubeke kuphela uma bungekho ubuhlungu abuzwayo.

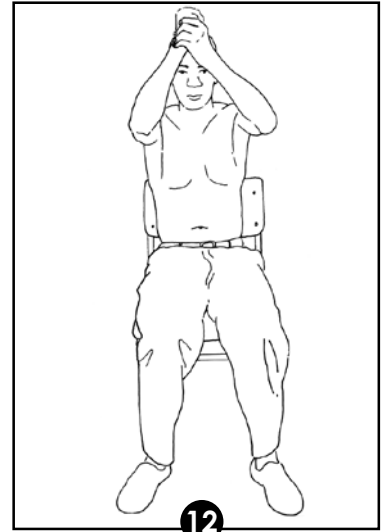

12

Qhubeka nokukhuphula izandla zize zifinyelele okhakhayini. Kodwa kumele aqhubeke kuphela uma bungekho ubuhlungu abuzwayo.

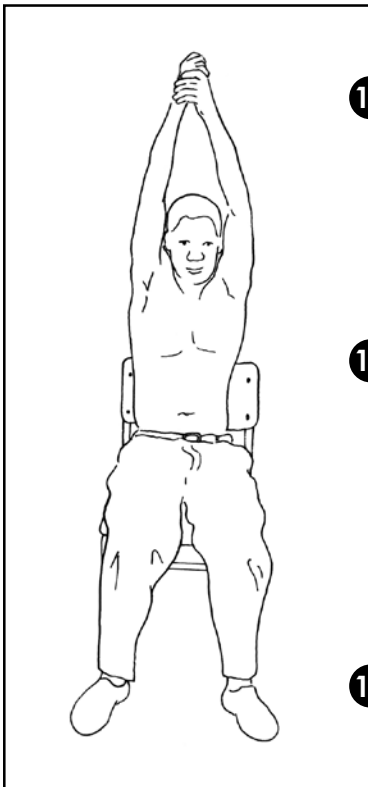

13

Uma ihlombe lakhe lingebuhlungu futhi lingaqinile, kumele alule izingalo ziye phezulu kakhulu, kodwa lokho kumele akwenze ngaphandle kokuzizwisa ubuhlungu.

14

Le ndlela yokuzivocavoca kumele ayiphindaphinde izikhathi ezinhlanu kuya kweziyishumi ngehlandla elilodwa lokuzivocavoca, okungenani kanye ngosuku. Njalo uma ezivocavoca kumele umcele ukuthi azame ukulula amajoyinti akhe kakhudlwana kunangaphambili.

15

Ungaqhubeki nokwelula umzimba uma lokho kudala izinhlungu. Uma kubuhlungu, kumele ayeke ukuzelula kodwa aphinde kuphela lezo zinyathelo zokuzivocavoca azenze phambilini.

7. Ukususa nokuphendula umuntu embhedeni

Imihlahlandlela ejwayelekile yokumphendula/yokumsusa:

- Ungalokothi umdonse ngengalo noma ngomlenze.
- Kumele ngaso sonke isikhathi umchazele ukuthi yini ofuna ukuyenza.
- Kumele umcele alekelele lapho engalekelela khona.
- Kumele ube seduze kwakhe kodwa akufanele ugcine usumongamele ngokweqile aze angakwazi nokunyakaza ngokukhululeka.
- Gobisa amadolo akho, kodwa ugcine umhlane wakho uqondile.



Bamphendula/bamsusa kanjani abantu ababili umuntu ongakwazi nakancane ukuzenzela lokhu ngokwakhe?

Embhedeni ophansi ngokuphakama

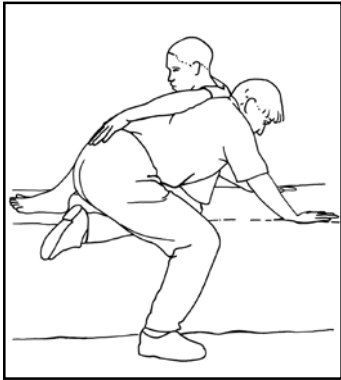

1. Makahlale ngezinqe bese egobisa amadolo akhe.
2. Bobabili abanakekeli kumele baguqe ngamadolo, babheke ngakumuntu onesifo sohlangothi, oyedwa abe ngapha kombhede omunye abe ngale kombhede.
3. Abanakekeli kumele babeke amahlombe abo ngapha nangapha ezinhlangothini zomzimba wakhe, ngaphansana kancane kwamakhwapha. Umuntu ohlaselwe yisifo sohlangothi angabeka ingalo yakhe enamandla emhlane womnakekeli.
4. Abanakekeli kumele baqaphele bangafaki amahlombe amakhwapheni omuntu ohlaselwe yisifo sohlangothi.
5. Umnakekeli ngamunye kumele azisekele ngalesi esinye isandla sakhe esikude nomuntu ohlaselwe yisifo sohlangothi.
6. Umnakekeli ngamunye kumele agaxe lesi esinye isandla kwingxenye yomlenze engaphezu kwedolo eseduze nezinqe.



7. Bobabili abanakekeli kumele bacindezele amahlombe abo emzimbeni womuntu onesifo sohlangothi.
8. Umnakekeli ngamunye kumele asebenzise ingalo yakhe eseduze komuntu onesifo sohlangothi ukubamba aqinise emlenzeni womuntu onesifo sohlangothi, eduze kwesinqe.
9. Abanakekeli kumele baqinisekise ukuthi babambe kahle futhi ngokuqinile, bese umlekeleli ngamunye eqondisa umlenze wakhe ongaphandle bese bephakamisa umuntu, bamgudlule lapho ebehleli khona.
10. Uma kungumuntu omkhulu ngokomzimba noma kungumuntu osindayo, esikhundleni sokubambelela ngalesi esinye isandla umnakekeli angabeka lesi sandla ezinqeni zomuntu onesifo sohlangothi ukuze kuphakanyiswe umuntu osindayo.

Embhedeni ophakeme

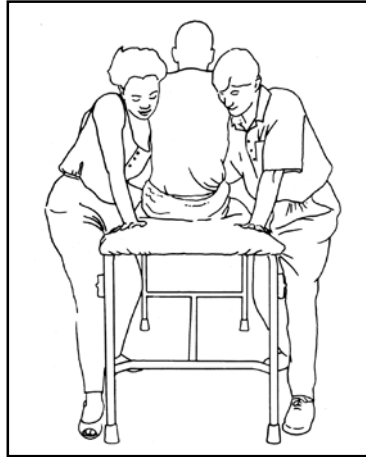
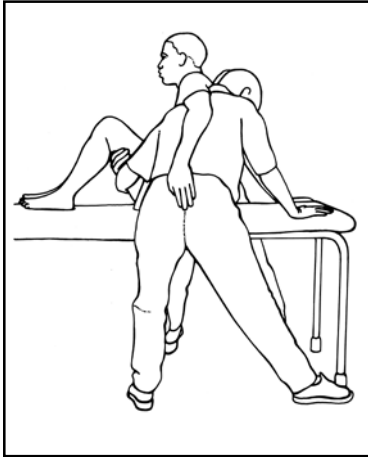

1. Makahlale ngezinqe bese egobisa amadolo akhe.
2. Bobabili abanakekeli kumele bame ngezinyawo, babheke ngakumuntu onesifo sohlangothi; oyedwa abe ngapha kombhede omunye abe ngale kombhede.
3. Izinyawo zomnakekeli kumele zigqagqane ngebanga elilingana nebanga lokugqagqana kwamahlombe, futhi unyawo lwakhe olungemuva kumele luqondane nomzimba womuntu onesifo sohlangothi. Izinyawo zomnakekeli kumele zibheke ngalapho bezomgudlulela ngakhona umuntu.
4. Abanakekeli kumele babeke amahlombe abo emzimbeni wakhe, ngaphansana kancane kwamakhwapha, kumele baqaphele bangafaki amahlombe amakhwapheni omuntu onesifo sohlangothi. Umuntu onesifo sohlangothi angabeka ingalo yakhe enamandla emhlane womnakekeli.
5. Umnakekeli ngamunye kumele azimelele ngalesi esinye isandla esikude nomuntu onesifo sohlangothi.

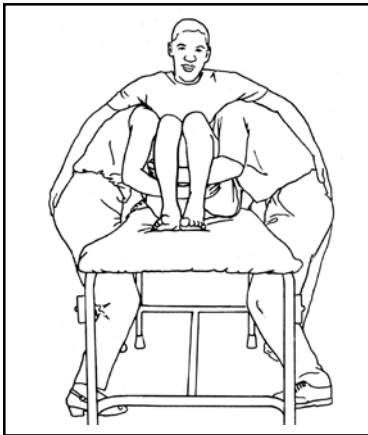

6. Abanakekeli kumele bagaxe izandla zabo kwingxenywe yomlenze wakhe engaphezu kwedolo eduze nezinqe.
7. Ukuze bamphakamise, kumele bacindezele amahlombe abo emzimbeni wakhe, bagaxe izandla zabo emilenzeni yakhe, babambe baqinise.
8. Uma kungumuntu omkhulu ngokomzimba noma kungumuntu osindayo, esikhundleni sokubambelela ngalesi esinye isandla umnakekeli angabeka lesa sandla ezinqeni zomuntu onesifo sohlangothi ukuze bamphakamise.

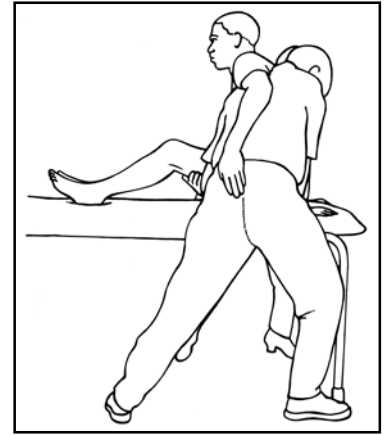

9. Abanakekeli kumele bamphakamise ngokuthi baqondise amadolo abo futhi ngokuthi badlulisele isindo sabo onyaweni lwabo olungaphambili, kanye nasezingalweni zabo ababambe ngazo.



Ngingamsiza kanjani umuntu okwaziyo ukuzinyakazela ngokwakhe kancane?

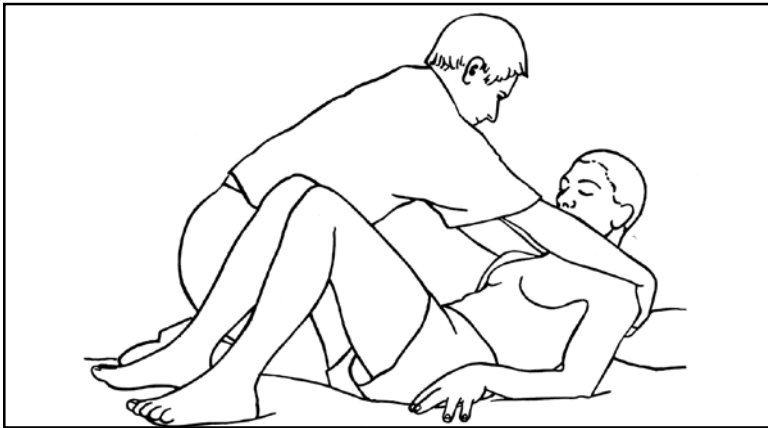
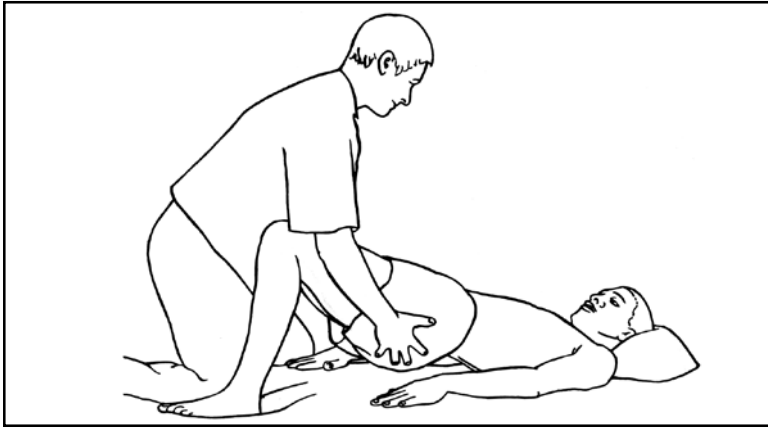

1. Guqa ngedolo elilodwa embhedeni eceleni komuntu onesifo sohlangothi.
2. Mlekelele ukuthi agobise amadolo akhe.
3. Izinyawo zakhe kumele zihlale mba embedeni. Beka idolo lakho phambi kwezinyawo zakhe ukuze zingasheleli.
4. Mlekelele ukuthi aphakamise izinqulu zakhe.
5. Bese umlekelela ukuthi ahambise izinqulu zakhe ziye eceleni.
6. Mbambe umqinise emva kwamahlombe.
7. Mcele ukuthi aphakamise ikhanda lakhe.
8. Mlekelele ukuthi aphakamise futhi anyakazise ikhanda lakhe kanye namahlombe akhe ngokuthi ubambe amahlombe akhe.
9. Ungamdonsi ngomqala noma ngezingalo.
10. Mgudlule aye eceleni ngokuthi uqale ngokuphakamisa ikhanda lakhe ulise eceleni bese ulandelisa ngamahlombe akhe, emva kwalokho ulandelise ngezinqulu zakhe.

Indlela yokuphendula umuntu ukuze alale ngohlangothi lwakhe olubuthakathaka noma uhlangothi lwakhe olunamandla

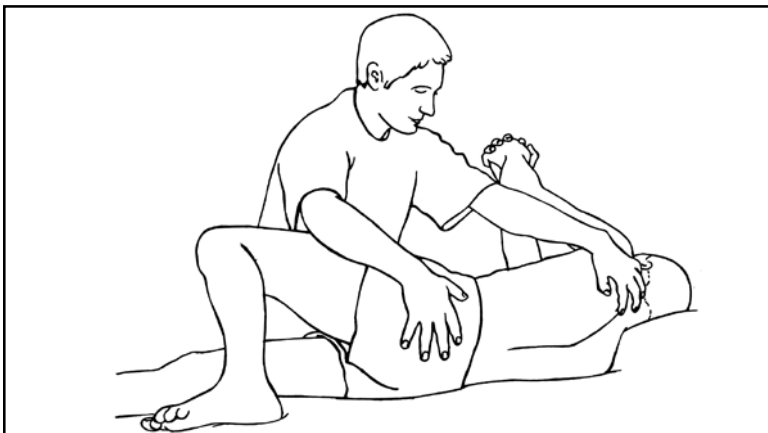

1. Mcele ukuthi abambe izandla zakhe azihlanganise noma abambe ingalo ebuthakathaka ngaphansi kwesihlakala, isithupha sakhe sibheke ngaseminweni. Umuntu kumele alule ngobunono isiphanga sakhe esibuthakathaka siye phambili.
2. Gobisa idolo okumele liphendulwe, bese emva kwalokho ephendula umzimba wakhe.
3. Mcele ukuthi aphakamise ikhanda namahlombe.
4. Msekele ezinqulwini zakhe kanye nasesiphangeni.

Indlela yokulekelela umuntu ocambalele ukuze avuke ahlale ngezinqe

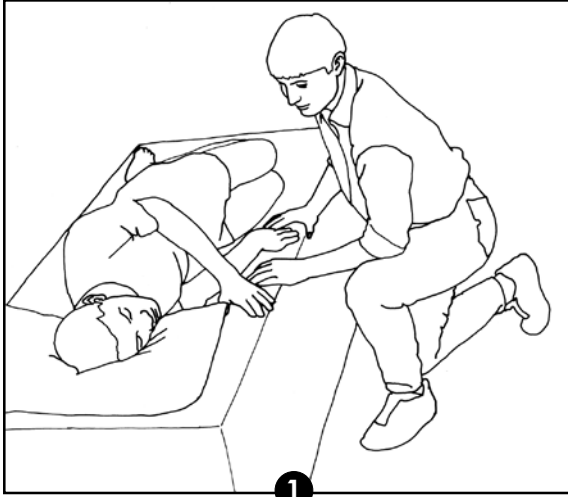

Mphendule alale ngohlangothi lwakhe.

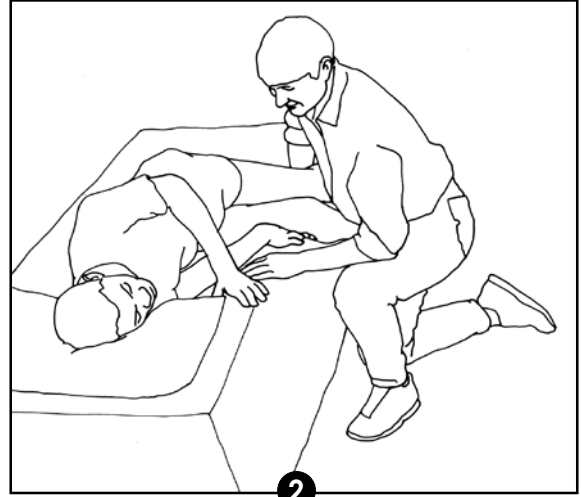

Jikisa imilenze yakhe ukuze ilenge onqenge-
meni lombhede.

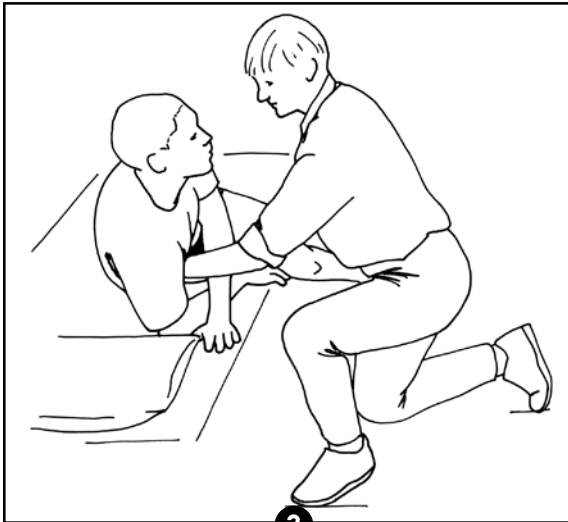

Ungamsekela ngokuthi umbambe nge-
sandla esisodwa ngaphansi kwezimbambo
bese lesi esinye isandla sibamba ihlombe
noma umsekele ngokubeka izandla zombili
emahlombe akhe.
Ungamsekela futhi ngokuthi ubeke isandla
esisodwa ehlobo lakhe bese esinye
isandla usibeka enqulwini yakhe.



Mcele ukuthi abambebelele embhedeni
ngezandla zakhe zombili bese ephakamisa
umzimba wakhe ukuze ahlale ngezinqe.
Ungamvumeli ukuthi abambebelele kuwena
noma adonse intamo yakho.

? Ngingambonisa kanjani indlela yokunyakaza embhedeni ngaphandle kosizo lomunye umuntu?

Indlela yokunyakazisa umuntu embhedeni

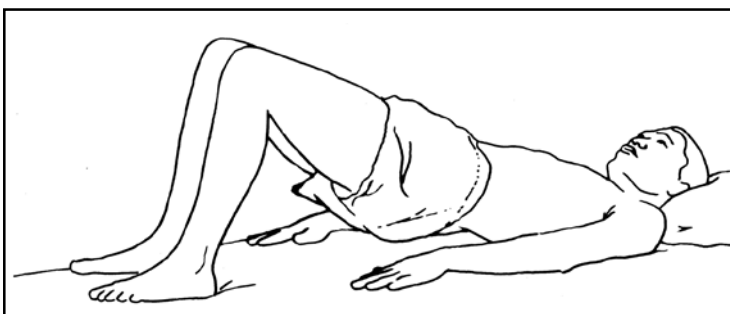

Mcele ukuthi:

1. Agobise amadolo akhe.
2. Izinyawo zakhe azibeke zithi mba embhedeni.
3. Aphakamise izinqulu zakhe ngokuthi azimelele ngezinyawo zakhe.
4. Agudlukele eceleni noma aphakame.
5. Aphakamise ikhanda lakhe namahlombe bese egudluka.

Indlela yokuphenduphenduka embhedeni

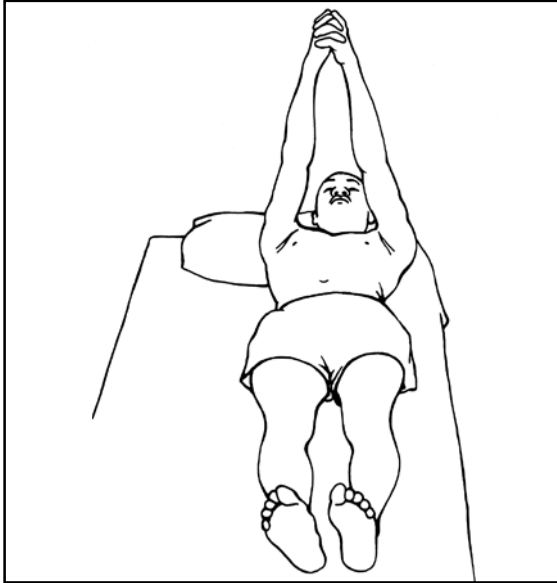

Mcele ukuthi:

1. Agudlukele eceleni embhedeni nje-
ngoba kuchaziwe ngenhla.
2. Abambe izandla zakhe azihlanganise
noma abambe ingalo ebuthakathaka
ngaphansi kwesihlakala, isithupha sakhe
sibheke ngaseminweni. Umuntu kumele
alule ngobunono isiphanga sakhe esi-
buthakathaka siye phambili.

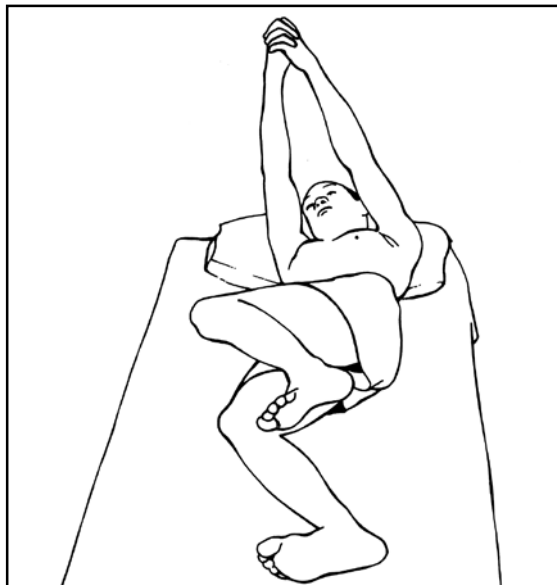

3. Aphakamise izingalo zakhe bese elula
ngobunono isiphanga sakhe esibu-
thakathaka siye phambili.
4. Aphakamise ikhanda, amahlombe
kanye nemilenze.

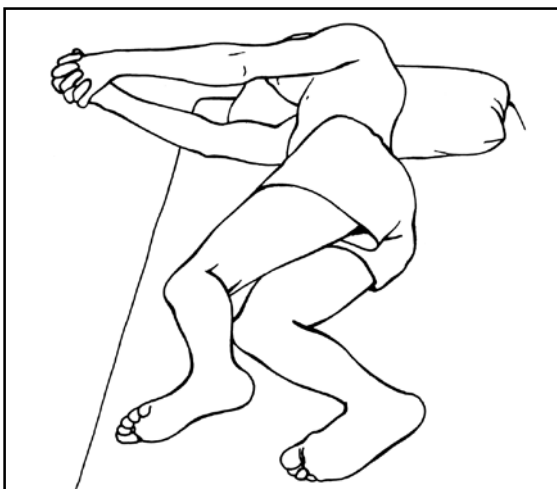

5. Aphendukele ngakolunye uhlangothi.

Indlela yokusukuma

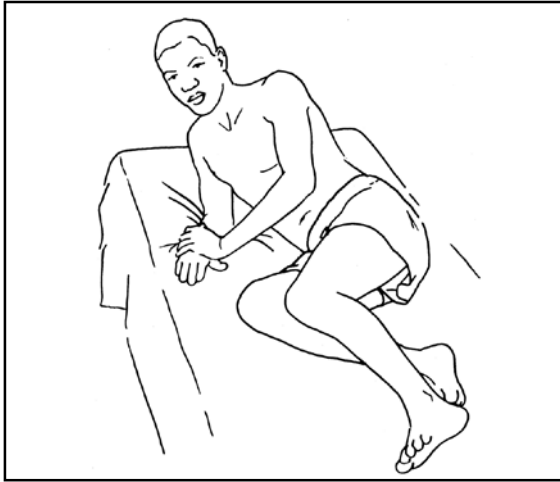

Mcele ukuthi:

1. Aphenduke alale ngohlangothi.
2. Agaxe unyawo olunamandla emva konyawo olubuthakathaka bese ejikisa imilenze ukuze ilenge onqenqemeni lombhede.

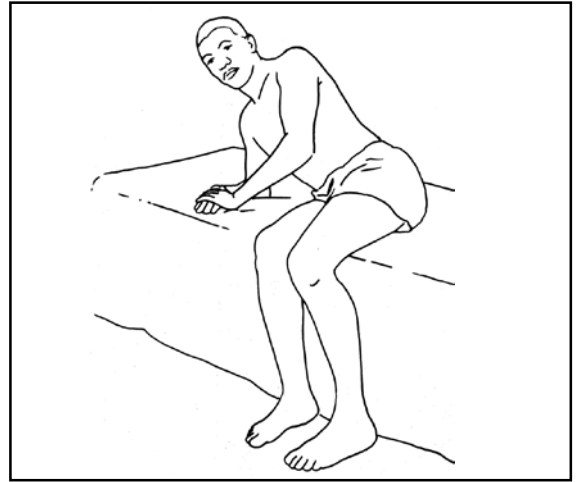

3. Makaphakame alale ngendololwane nokuthi azimelele phansi ngezingalo zombili.

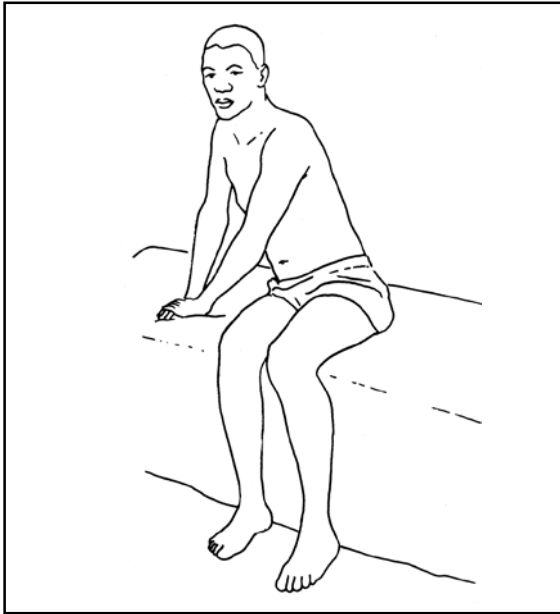

4. Makaqhubeke nokuzimelela ngezandla zombili bese eqondisa indololwane.

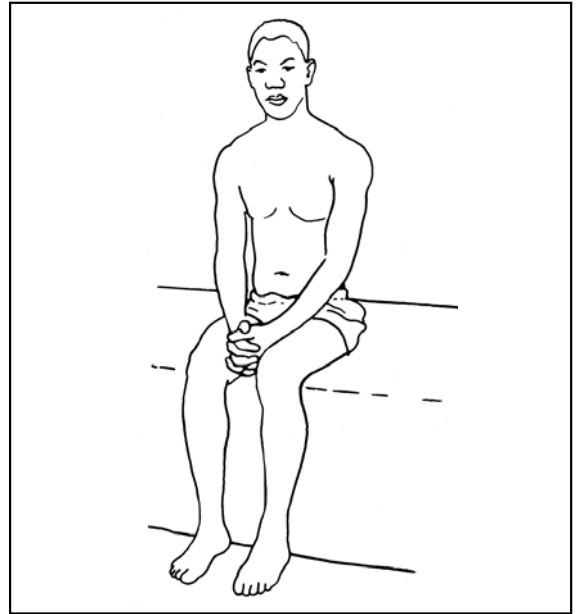

5. Makaphakame ngokuphelele ukuze ahlale aqonde futhi aqinisekise ukuthi uhleli emuva ngokwanele ukuze umbhede usekele amathanga akhe ngokuphelele.

8. Indlela yokususa umuntu umbeke kwenye indawo (indlela yokumsusa embhedeni umbeke esihlalweni)

Imihlahlandlela ejwayelekile:

- Sondeza isihlalo esinamasondo noma isihlalo esijwayelekile eduze kombhede.
- Bopha amabhuleki esihlalo esinamasondo.
- Umnakekeli kumele noma onamandla kumele abe ngasemuva.
- Abanakekeli kumele basebenze ngokubambisana.
- Ngaphambi kokuqala umsebenzi kumele nithathe isinqumo sokuthi ngubani phakathi kwenu ozonikeza imiyalelo, nokuthi yimiphi le miyalelo okumele inikezwe.
- Kumele kube khona indlela okhombisa ngayo ukuthi uzoqala nini ukuphakamisa, lokho ungakwenza ngokuphakamisa emva kokubala "kathathu" noma uthi: 'Kunye, kubili, phakamisa.



Bangamsusa kanjani esihlalweni abantu ababili umuntu obuthakathaka kakhulu bambeke embhedeni omfushane?



Indlela ahleli ngayo umuntu onesifo sohlangothi:

1. Usonge izandla.



Ukuma kwabanakekeli:

2. Umnakekeli ongasemuva ufaka izandla zakhe phakathi kwengxenywe yezingalo engenhla kwendololwane kanye nezimbambo.
3. Umnakekeli ubamba umikhono yomuntu eduze kwezindololwane.



Ukuma komnakekeli ongaphambili:

4. Lo mnakekeli kumele aguqe noma aqoshame phambi kombhede, unyawo olulodwa lube phambi kolunye.
5. Umnakekeli ubeka izingalo zakhe ngaphansi kwamadolo namathanga omuntu onesifo sohlangothi, eduze kakhulu kwezinqe zakhe.
6. Izinyawo zomuntu onesifo sohlangothi angazibeka phezu kwamathanga omnakekeli, kodwa futhi kungenzeka ukuthi vele ingxenywe yazo seyihleli phezu kombhede.



Okumele kwenziwe ngumnakekeli ongaphambili:

7. Umnakekeli ongaphambili kumele aphakamise izinyawo zomuntu onesifo sohlangothi, futhi azibambe zisondele emzimbeni wakhe, bese edlulisela isisindo phambili kulona omunye umlenze ukuze akwazi ukudlulisela umuntu embhedeni.

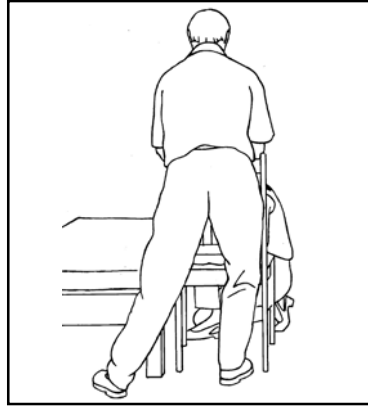

Okumele kwenziwe ngumnakekeli ongasemuva:

8. Umnakekeli ongasemuva kumele ame ngezinyawo agxamalaze futhi agobise imilenze yakhe kancane, bese eyiqondisa imilenze ukuze aphakamise umuntu. Umnakekeli angaligobisa futhi idolo eliseduze kombhede ukuze aguqe ngalo phezu kombhede.

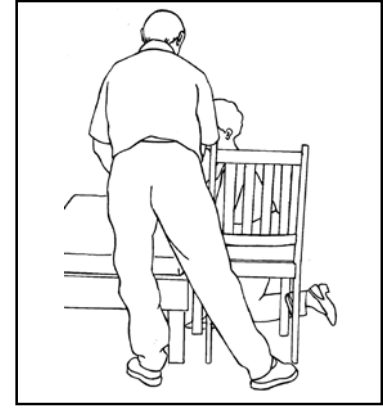

Okumele kwenziwe ngumnakekeli ongasemuva:

9. Umnakekeli ongasemuva kumele manje adlulisela isisindo sakhe onyaweni lwakhe oluseduze kombhede bese edlulisela umuntu phezu kombhede.

Ukususa umuntu embhedeni umbeke esihlalweni kumele ulandele lezi zinyathelo ezingenhla, kodwa kumele uzihlanekezele.



Bangamsusa kanjani esihlalweni abantu ababili umuntu obuthakathaka kakhulu bambeke embhedeni ophakeme kakhulu?

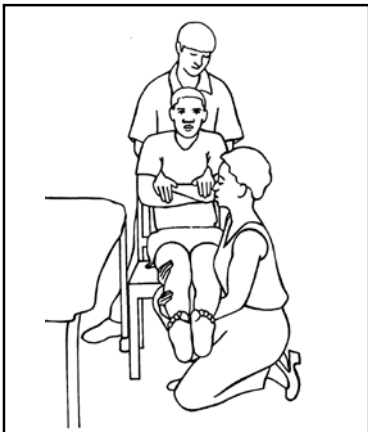

1. Abanakekeli kumele bame ngendlela echazwe ngenhla. Umnakekeli ongaphambili kumele aguqe noma aqoshame, umlenze owodwa ube phambi komunye.
2. Imilenze yomuntu onesifo sohlangothi kumele ibekwe phezu kwamathanga omnakekeli.



3. Umnakekeli ongasemuva kumele aphakamise umuntu ngendlela echazwe ngenhla. Uma umnakekeli emfushane kumele ame phezu kwento ethile eqinile.
4. Umnakekeli ongaphambili uphakamisa izinqe nezinyawo zomuntu onesifo sohlangothi ngokuthi asukume.

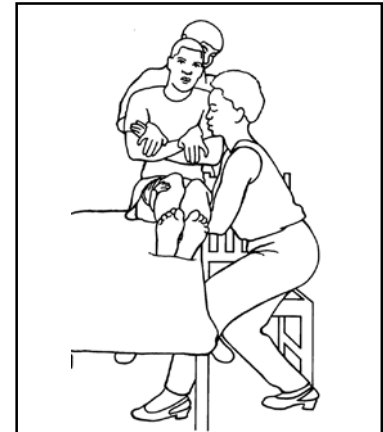

5. Umnakekeli ongasemuva udlulisela isindo sakhe emlenzeni wakhe oseduze kombhede bese edlulisela umuntu embhedeni.
6. Umnakekeli ongaphambili uhambisa phambili unyawo lwakhe lwangemuva bese edlulisela izinyawo nezinqe zomuntu onesifo sohlangothi embhedeni.

Ukususa umuntu embhedeni umbuyisele esihlalweni kumele ulandele lezi zinyathelo ezingenhla, kodwa kumele uzihlanekezele.



Angamsiza kanjani umuntu oyedwa umuntu ukuthi asuke embhedeni ayohlala esihlalweni?

Imihlahlandlela ejwayelekile yilena elandelayo:

- Lekelela umuntu ukuthi asondele phambili ngesinqe esihlalweni noma embhedeni.
- Gxamalazisa izinyawo zakhe kancane, futhi kumele zibe ngasemuva kwamadolo.
- Mcele ukuthi aqinisekise ukuthi umhlane wakhe uqondile, agobise izinqulu bese egebi-sa ikhanda namahlombe kuye phambili phezu kwamadolo.
- Qaphela ungasondeli kakhulu kuyena. Hlehlisa umzimba wakho ngenkathi yena esondela phambili.
- Mcele ukuthi ame ngezinyawo aqonde ngenkathi kuphakanyiswa isingezansi sakhe.



Indlela yokunyakazisa umuntu ome ngezinyawo odinga ukusekelwa edolweni elibuthakathaka

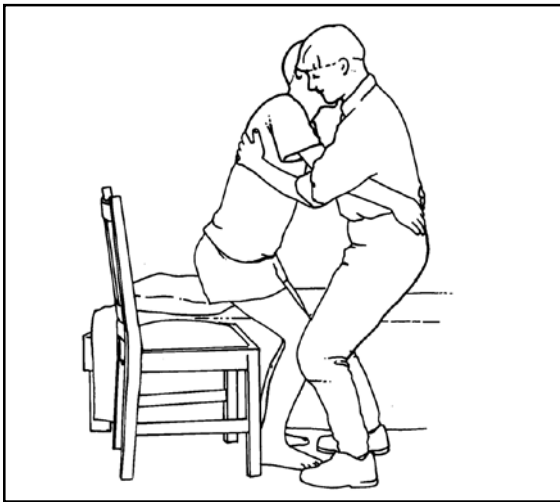

1. Beka isihlalo eduze kombhede.
2. Sekela idolo lakhe ezinhlangothini zombili ngokusebenzisa amadolo akho. Ungalivimbeli idolo ngaphambili.

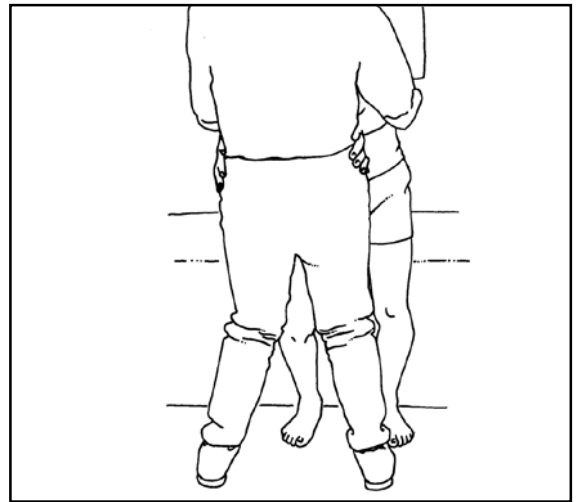

3. Sondeza umuntu phambili futhi umphakamisele phezu ngokuthi uhambise amahlombe akhe phambili bese uwaphakamisa.
4. Jikisa umzimba wakho uye ngasembhedeni bese umhlalisa embhedeni phansi ngubunono.

Umnyakazisa kanjani umuntu ongenamandla, onesisindo esingaphezu kwesakho noma omude kunawe, usebenzisa uqwembe olushushuluzayo

Sebenzisa uqwembe oluyisicaba umuntu angashishiliza kulona. Qinisekisa ukuthi ingaphezulu loqwembe kanye nonqenqema lwalo akunazo izingcezwana zokhuni ezihlabayo. Kumele uqwembe lusetshenziswe kuphela uma umuntu egqokile.

Isilinganiso sobude nobubanzi boqwembe kanye neminingwane ephathelene nendlela yokwakha lolu qwembe

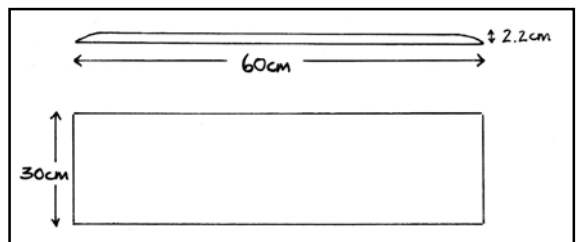
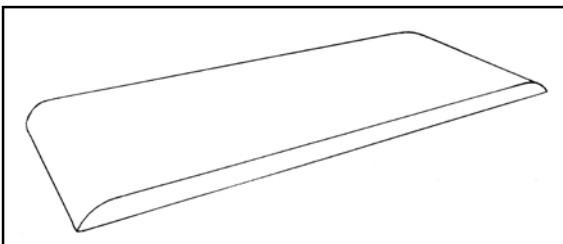

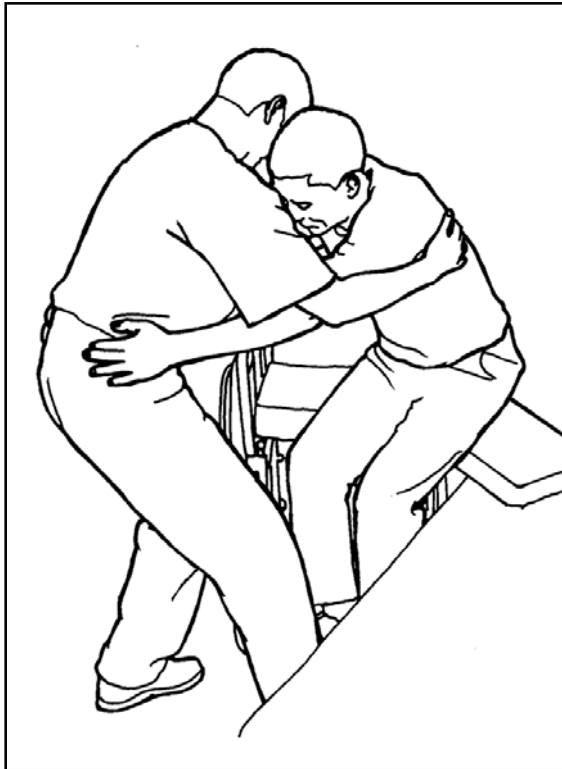

1. Beka isihlalo esinamasondo eceleni kombhede, futhi kumele sitsheke kancane. Bopha amabhuleki. Susa ingxanye yesihlalo yokubeka isandla eseduze kombhede.
2. Yima ngendlela ovamise ukuma ngayo uma uqudlula umuntu ngenkathi ume ngezinyawo.
3. Mdonse kancane athi ukuphakama embhedeni bese ufaka uqwembe ngaphansi kwesinqe sakhe esiseduze kombhede.
4. Beka uqwembe ngendlela yokuthi lwenze ibhuloho phakathi kombhede nesihlalo esihamba ngamasondo.
5. Mcele ukuthi agcine umhlane wakhe uqondile bese esondela phambili ngekhandalakhe kanye namahlombe phezu kwamadolo.
6. Hambisa isinqe sakhe ngenkathi isisindo sakhe sisuka phezu koqwembe.
7. Uma umuntu ebuthakathaka, mhambise kuphela ibangana elifushane. Kuphindaphinde lokhu aze ahlale phezu kombhede.
8. Hlanekezela lezi zinyathelo uma usumbuyisela esihlalweni esinamasondo.

Indlela yokulekelela umuntu onezingalo ezinamandla kanye nemilenze ebuthakathaka ukuthi asuke lapho ehleli khona

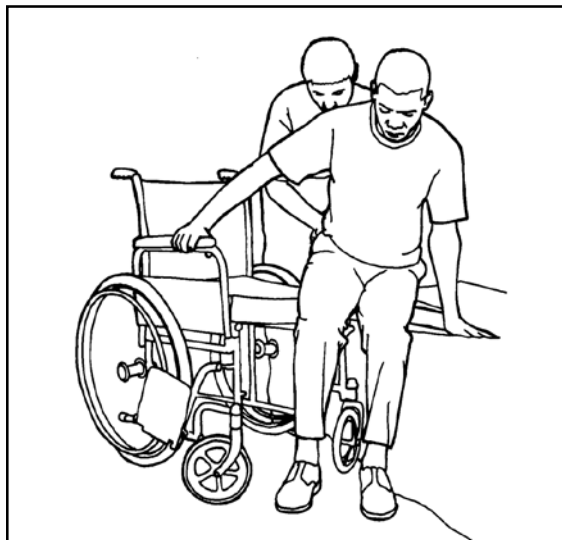

1. Faka uqwembe njengoba kuchaziwe ngenhla.
2. Yima emva kwakhe bese uguqa embhedeni ngomlenze wakho oseduze kakhulu nombhede. Beka lona omunye umlenze phakathi kombhede nesihlalo esinamasondo.
3. Beka izandla zakhe ezinqulwini zakhe.

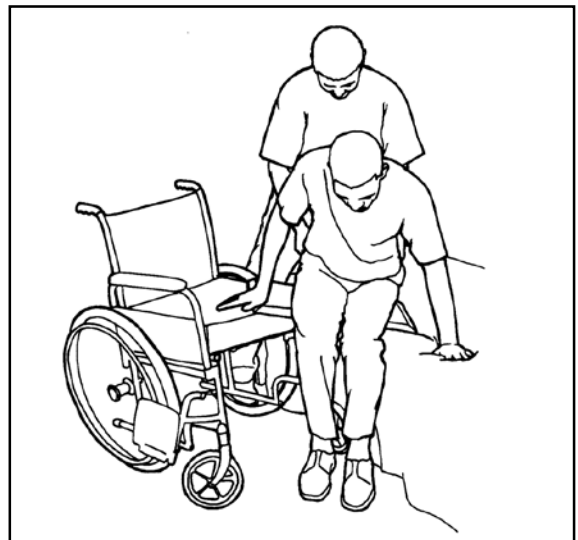

4. Mcele ukuthi azimelele ngezandla zakhe bese ephakama futhi aguqulule isinqe sakhe siye eceleni.
5. Mlekelele ukuthi aphakame bese egudlula isinqe sakhe siye eceleni.
6. Kuphindaphinde lokhu aze ahlale embhedeni noma esihlalweni.



Ngingambonisa kanjani umuntu onemilenze ebuthakathaka kanye nezingalo ezinamandla ukuthi asuke esihlalweni ayohlala embhedeni ngaphandle kokulekelelwa ngomunye umuntu?

Ngokusebenzisa uqwembe lokushishiliza



1. Faka uqwembe ngaphansi kwesinqe sakho.
2. Sondela phambili futhi ingxenye yesisindo somzimba uyibeke ezinyaweni zakho.
3. Zimelela ngezingalo.
4. Suka lapho uhleli khona ngokuthi ushishilize ngesinqe kancane kancane uye eceleni.
5. Ungasukumi ngokuphelele.



Ngingamsiza kanjani umuntu ukuthi asukume ngokulekelelwa okuncane?



1. Mlekelele ukuthi asondeze isinqe sakhe onqenqemeni lombhede.
2. Izinyawo zakhe kumele zigqagane kancane, ziqondane futhi zibe ngasemuva kancane kwamadolo.



3. Sekela ingalo ebuthakathaka ngenqulu yakho. Uma ingalo igongobele noma ibuhlungu, iyeke ilenge phakathi kwamadolo akhe.



4. Mbambe esiphange-ni emzimbeni, hhayi kwingxenye yengalo engenhla kwendololwane. Sekela ingalo yakhe ngomkhono wakho.

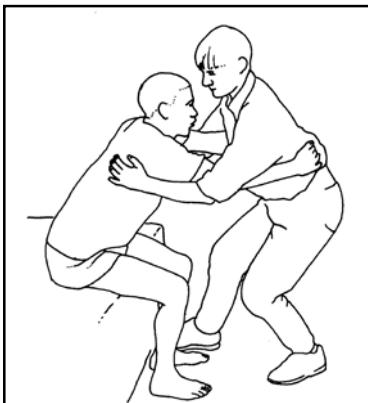

5. Lekelela amahlombe akhe eze phambili ngokuthi udlulisele isindo sakho emlenzeni wakho wange-muva.



6. Mlekelele ukuthi ame ngezinyawo. Kumele umvumele ukuthi azenzele ngokwakhe izinto eziningi.



Ngingamsiza kanjani umuntu ukuthi asukume ame ngezinyawo zakhe ngaphandle kokulekelelwa?

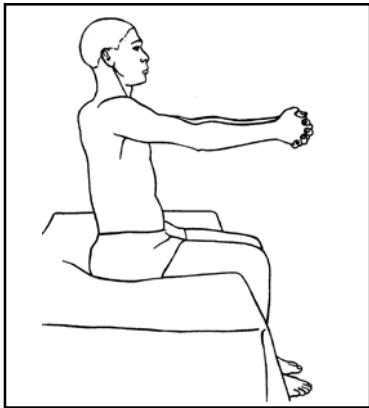

1. Hlala uqonde.
2. Hlanganisa izandla zakho noma ubambe ingalo yakho ebuthakathaka ngaphansana kancane kwesihlakala, isithupha sakho sikhombe ngaseminweni.

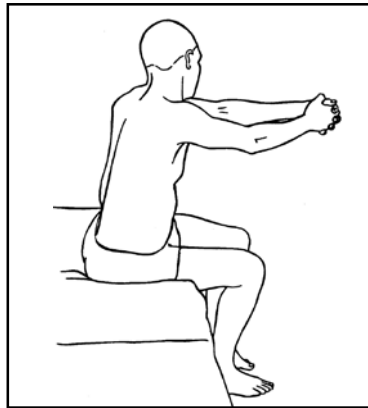

3. Sondeza isinqe sakho phambili.

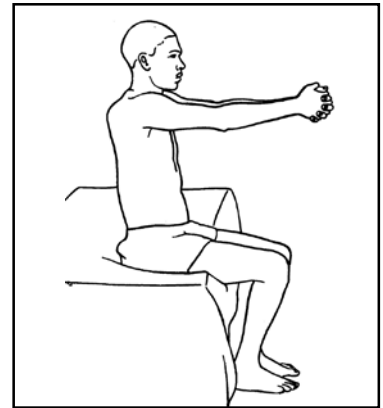

4. Hlala onqeqemeni lombhede. Gqagqanisa izinyawo kancane, ziqondane futhi zibe ngasemuva kancane kwamadolo.

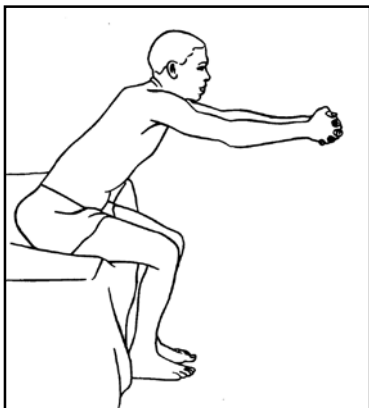

5. Sondela phambili ngezinqulu, amahlombe aze abe phambi kwamadolo kanye nemilenze. Lula izandla zakho ziye phambili ukulekelela ukuthi isisindo size phambili.

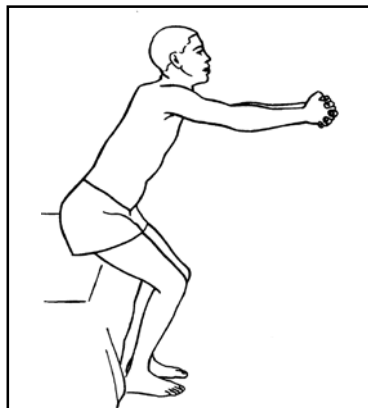

6. Qala ukuphakamisa isinqe bese uqondisa amadolo. Ungawancikisi amadolo emuva embhedeni noma esihlalweni.

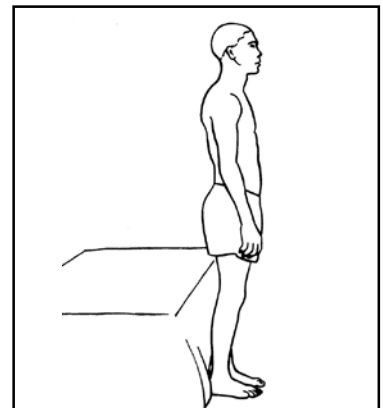

7. Sukuma ume uqonde.

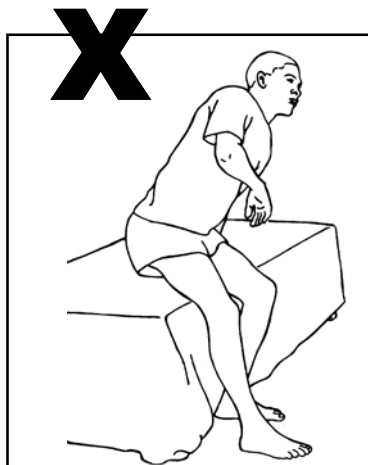

Ungasukumi ngokuzimelela ngesandla esinamandla kuphela. Uma umuntu esebenzisa kuphela uhlangothi lwakhe olunamandla, lokho kuzobangela ukuthi aphelelwe amandla futhi luzogongobala uhlangothi lwakhe olubuthakathaka. Esikhundleni salokho kungaba ngcono uma elula izandla zakhe zombili ziye phambili bese ezibeka phezu kwengxenywe engemuva yesihlalo, noma obondenini noma azibeke entweni ethile eyifenisha yasendlini ukuze akwazi ukuzimelela ngayo.

9. Ukuzinakekela komuntu ngokwakhe

Ukulawula isinye kanye nokuzithuma (izidingo zasendlini encane)

Ziningi izizathu ezingenza ukuthi abantu bakuthole kunzima ukulawula izinye zabo noma ukuzithuma. Umuntu onale nkinga kumele abonane nodokotela, ozokwelapha ezinye zalezi zinkinga futhi amnikeze imithi ezomsiza ukuthi akwazi ukulawula lokhu kangcono.



Kumele umvumele ukuthi azenzele izinto eziningi ngokwakhe.



Indlela yokulekelela umuntu ukuthi akwazi ukulawula isinye sakhe

Mchazele imihlahlandlela ejwayelekile, kanje:

- "Phuza amanzi angamagilasi ayisithupha kuya kwayishiyagalombili ngosuku. Gcwalisa ngamanzi ibhodlela elingamalitha amabili nsukuzonke, bese ulifaka kwisiqandisi noma ulibeke eceleni kombhede noma eceleni kwesihlalo. Ungawunciphisi umthamo wamanzi owaphuzayo ngenxa yovalo lokuthi uzovelelwa yingozi yokuzichamela.
- Uma unenkinga yokuzichamela ebusuku ungaphuzi lutho okungenani esikhathini esiyihora ngaphambi kokuyolala.
- Vakashela endlini encane ngaphambi kancane nje kokuyolala, uphinde futhi ekuseni ngesikhathi uphaphama.
- Mboza umatilasi ngeshidi elakhiwe ngocwazi, bese umboza lowo cwazi ngethawula noma ngephephandaba, emva kwalokho ufake ishidi. Ungalali/Ungahlali ngqo phezu kwekhava yocwazi.
- Vakashela endlini encane njalo emva kwamahora amabili. Sikhuphule kancane kancane lesi sikhathi size sifinyelele ekuvakasheleni indlu encane njalo emva kwamahora amane.
- Umbala womchamo kumele ube mnyamana kancane kunamanzi. Uma umnyama kakhulu, unephunga elibi noma unegazi, phuthuma emtholampilo ukuze uxilongwe ukuthi awunaso yini isifo esithile. Esikhathini esiningi umchamo onombala omnyama uchaza ukuthi awuwaphuzi amanzi ngokwanele."

Uma esebenzisa ikhatetha (ithunjana lokuhambisa umchamo kwisigujana esiboshelwa emzimbeni):

- Kumele ngaso sonke isikhathi uhlanze izandla zakho ngaphambi kokusebenzisa ikhatetha, uphinde futhi uzihlanze emva kokuyisebenzisa.
- Kumele usithulule ngokuqhubekayo isigubhu.
- Ungasibophi usiqinise kakhulu isigubhu.
- Uma ungekho umchamo esigujini kuze kuphele amahora amane, kungenzeka ukuthi ithunjana lomchamo livalekile. Kumele umhambise emtholampilo.



Ungamsiza kanjani umuntu ongakwazi ukulawula ukuzithuma

- Udokotela kumele afake lowo muntu ngaphansi kohlelo lokusiza abantu abangakwazi ukulawula ukuzithuma uma izinzwa zakhe zingakwazi ukumtshela ukuthi kumele avakashele endlini encane.
- Beka inqubo yokuzithuma ezolandelwa ngokuqhubekayo, njengokuvakashela endlini encane njalo ekuseni emva kwesidlo sasekuseni.
- Kumele ahlale esihlalweni sendlu encane noma asebenzise isiqukathi esingumahambanendlwana esibekwa eduze kombhede.
- Ukuvimbela ukuqunjelwa:
 - Umuntu kumele aphuze izingilazi zamanzi eziyisithupha kuya kweziyisishiyagalombili ngosuku.
 - Umuntu kumele achithe isikhathi sakhe esiningi emini engekho embhedeni.
 - Umuntu kumele angahlali athi dekle, kodwa kumele akhuthale, abe matasatasa.
 - Kumele adle ukudla okumahhadlahadla (okunefayibha), isibonelo izithelo ezingacwecwiwe, imifino, izithelo ezomisiwe, amakhoba (bran), isinkwa esinsundu kanye ne-layisi elinsundu.
- Mphuthumise emtholampilo uma ehlaselwe yisifo sohudo esinganqamuki kuze kuphele izinsuku ezingaphezu kwezintathu.

? Sisetshenziswa kanjani isikigi?



Mvumele ukuthi asebenzise isikigi kuphela uma echama.

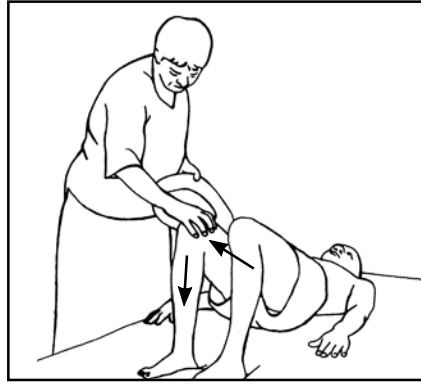

1. Sekela idolo lakhe elibuthakathaka ngesandla sakho ngenkathi ephakamisa izinqulu zakhe.
2. Donsa idolo liye phambili bese liya phansi phezu konyawo ukuze unyawo lungasheleli noma luputshuke luye phambili.

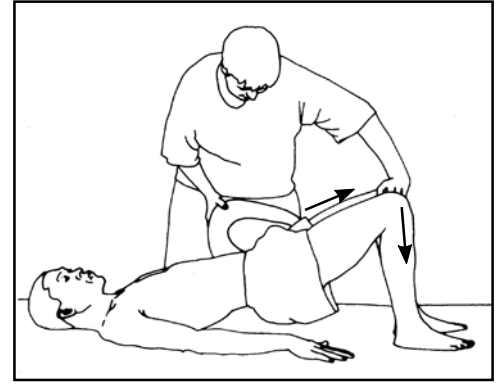

3. Faka isikigi.

? Umnakekeli oyedwa angamhambisa kanjani umuntu endlini encane?

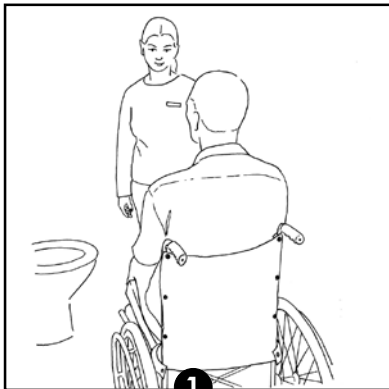

Uma kungelula ukuthi isihlalo esinamasondo sitshekiswe ngamadigri angama-90 phambi kwesihlalo sendlu encane, zama ukusitshekisa ngendlela enokwenzeka. Bopha amabhuleki.



Mlekelele ukuthi asondele mamaphambili esihlalweni bese esukuma.



Sekela idolo elibuthakathaka ngamadolo akho. Mbambe ezinqulwini zakhe ukuze angantengantengi.



Phenduka ukuze agcine eseme phambi kwesihlalo sendlu encane. Mlekelele ukuze akhumule izingubo azigqokile.



Mlekelele ukuthi ahlale phansi kancane kancane.



Usuka kanjani umuntu esihlalweni esinamasondo ahlale esihlalweni sendlu encane ngaphandle kokulekelelwa?



1. Bopha amabhuleki esihlalo esinamasondo bese usondela mamaphambili onqenqemeni lwesihlalo.
2. Bamba izandla uzihlanganise.
3. Sukuma.



4. Phenduka.
5. Beka izandla phezu kwesihlalo ngenkathi zihlanganisiwe ukuze uthole ukwesekeleka, uma kudingeka.



6. Hlala phezu kwesihlalo sendlu encane.
7. Uma kungelula ukuthi ume ngezinyawo ngaphandle kokusekelwa yizandla, sebenzisa umgoqo wokubambelela owenzelwe abantu abakhubazekile endlini encane, bese ulengisa izandla esibuthakathaka phakathi kwemilenze.



Izinto ezingaba wusizo kumuntu ngenkathi evakashela endlini encane



Isihlalo sendlu encane esiphakeme: Sisebenza kahle kubantu abade, noma kubantu asebekhulile abanekinga yokuhlushwa yizinqulu kanye namadolo, noma abanekinga yokusebenzisa isihlalo sendlu encane esiphansi kakhulu.

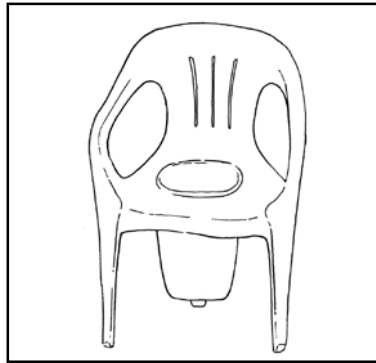

Isihlalo sepulastiki esinembobo yokuzikhulula kanye nebhakede ngaphansi.

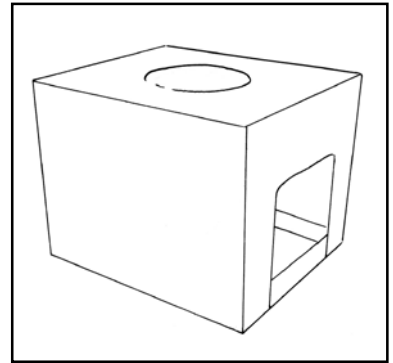

Yakha indlu yangasese engumahambanendlwana eyakhiwe ngokhuni.

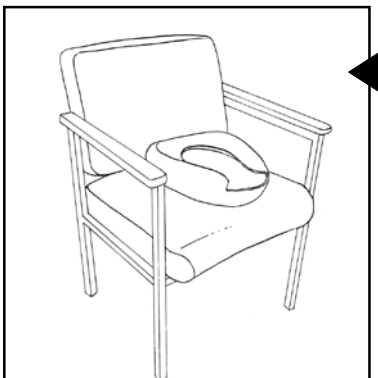

Sebenzisa isikigi esibekwe esihlalweni esinendawo yokuhlala eqinile.

Sebenzisa isikigi esibekwe phezu kwesihlalo esinamasondo.

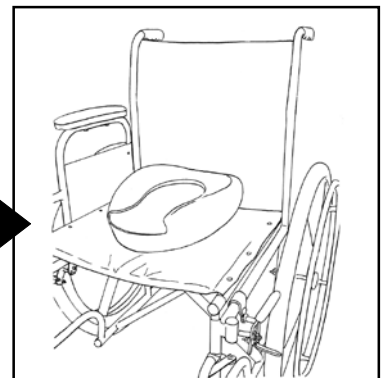

Ukugeza

Ngimgeza kanjani umuntu esembhedeni?

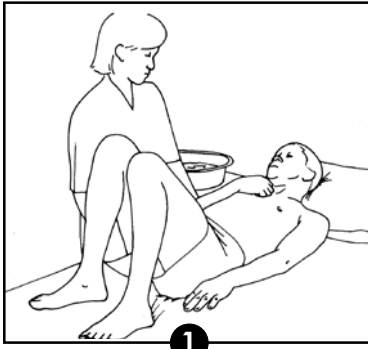

Yima ngezinyawo ngasohlangothini olubuthakathaka.

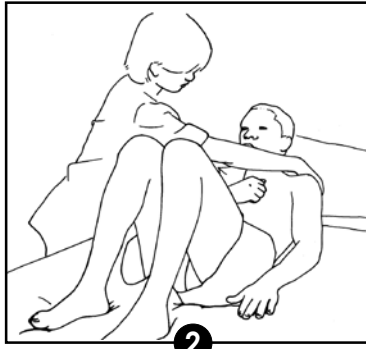

Msuse ohlangothini lombhede ngokuthi uphakamise ikhanda lakhe kanye namahlombe, umbeke mamaphakathi kombhede.

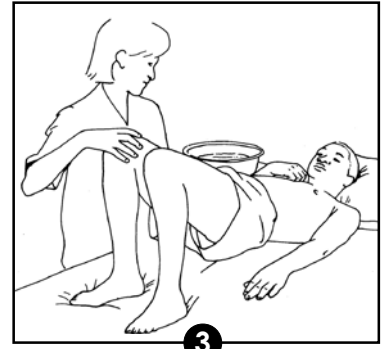

Mcele ukuthi aphakamise izinqulu zakhe ngokuphakamisa isinqe sakhe bese egudlukela mamaphakathi kombhede.



Xegisa ihlombe ngaphambi kokuthi uphakamise umbhede. Gaxa isandla sakho esiphangeni sakhe bese usidonsa ngobunono isiphanga usise ngaphandle bese usiletha phambili. Kuphindaphinde izikhathi ezimbadlwana lokhu kuze kufike isikhathi lapho ihlombe selinyakaza ngokukhululeka.

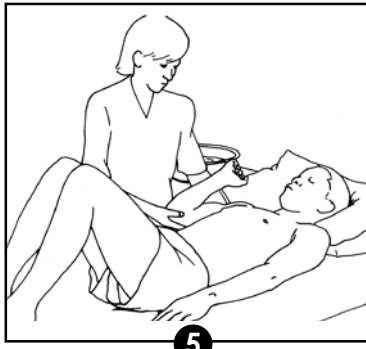

Bamba ingalo ngaphezudlwana nje kancane kwe-ndololwane bese uyiphendula ngokucophelela iye ngaphandle. Yeka ukwenza lokhu uma umuntu ezwa ubuhlungu. Ungabambi isandla noma ingxenye yengalo engezansi kwe-ndololwane ngoba lokho kungabanga izinhlungu noma kwenze umonakalo endololwaneni.



Qondisa indololwane.

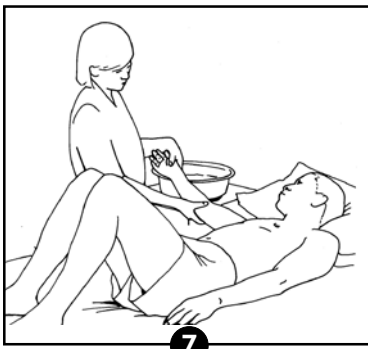

Qinisekisa ukuthi ingalo ijikile ibheke ngaphandle. Manje phakamisa ingalo iye phezulu noma iye phambili. Yeka ukwenza lokhu uma umuntu ezwa ubuhlungu.

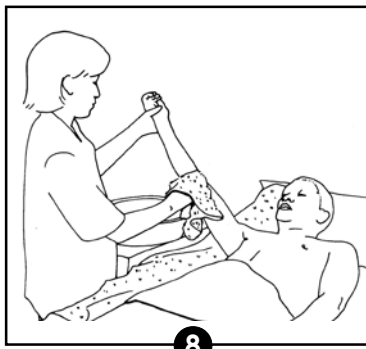

Geza futhi womise amakhwapha.

Ukugeza umhlane

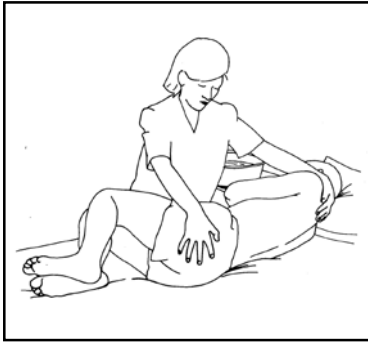

1. Xegisa ingalo ebuthakathaka njengoba kuchaziwe ngenhla. Qinisekisa ukuthi isiphanga sime phambidlana.
2. Beka ingalo ebuthakathaka ohlangothini ngaphambi kokumphendula.

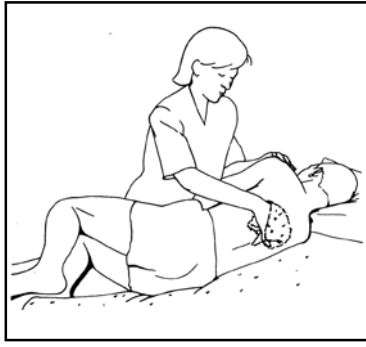

3. Mphendule alale ngohlangothi.
4. Mgeze emhlane.
5. Sebenzisa ithawula engxenyeni engaphansi komzimba.
6. Ngenkathi umuntu elele ngale ndlela, ungawashintsha amashidi.

Ukugeza ngaphansi komzimba

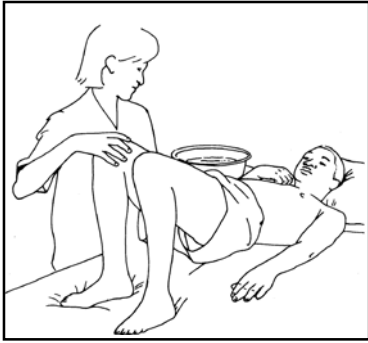

1. Sekela idolo elibuthakathaka ngenkathi umuntu ephakamisa izingqo zakhe.
2. Mgeze ngaphansi.



Angazigeza kanjani umuntu ngaphandle kokulekelelwa?

- Kumele ahlale onqenqemeni lombhede.
- Izinyawo kumele zihlale phansi noma kwibhulokhi lokhuni noma esitakini samaphephandaba noma kokhalibhodi ababoshelwe ndawonye.
- Beka itafula phambi kwakhe elinobheseni, ithawula lokugeza, insipho kanye nethawula lokusula umzimba.
- Ngenkathi egeza isingenhla sakhe, sekela isandla esibuthakathaka kanye nendolwane phezu kwetafula ukuze angawi, futhi ukuze uvimbele ukulimala kwengalo nesandla sakhe. Lokho kuzosiza futhi ukuthi akwazi ukufinyelela emakhwapheni akhe futhi akwazi nokugeza ingalo.

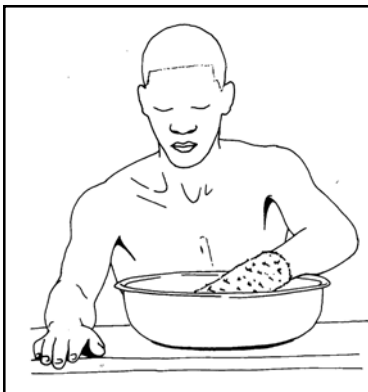

Manzisa ithawula lokugeza.

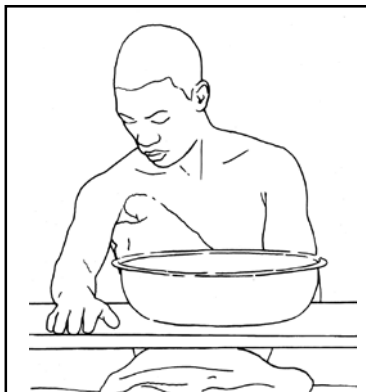

Geza ngaphansi kwengalo ebuthakathaka.

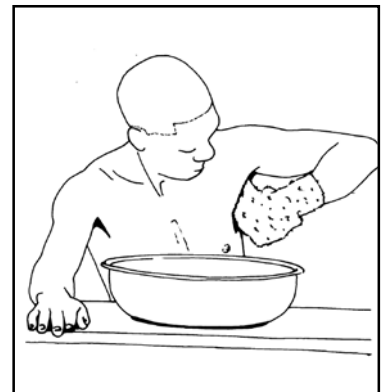

Geza ngaphansi kwengalo enamandla.

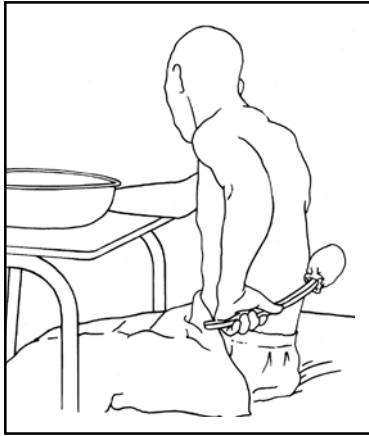

Geza emhlane ngebhulashi.

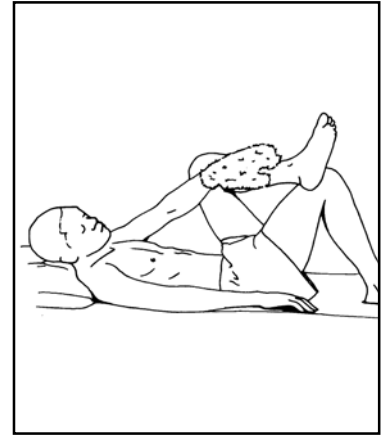

Uma ungakwazi ukuzi-melela kahle, lala phansi bese ugaxa iqakala phezu kwelinye ukuze ukwazi uku-geza imilenze nezinyawo.

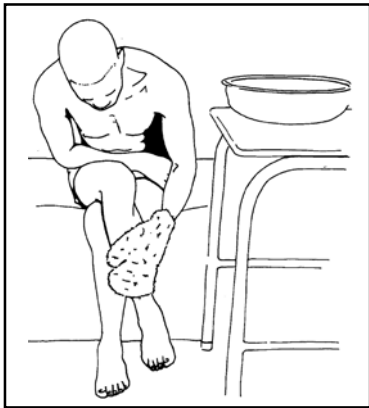

Geza imilenze nezinyawo uhleli phansi uma ungakwazi ukuzimelela kahle.

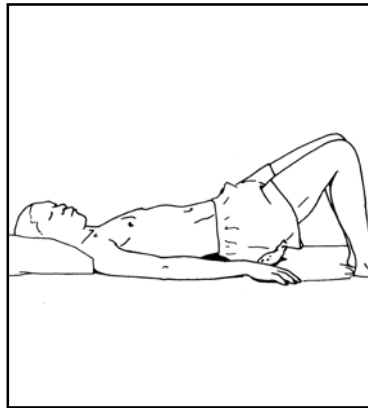

Lala phansi ukuze ugeze izingqe.



Endlini yokugezela sebenzisa umata wenjoloba ongashileli ukuze ungashileli uwele phansi.



Ngimsusa kanjani umuntu esihlalweni ngimbeke kubhavu?

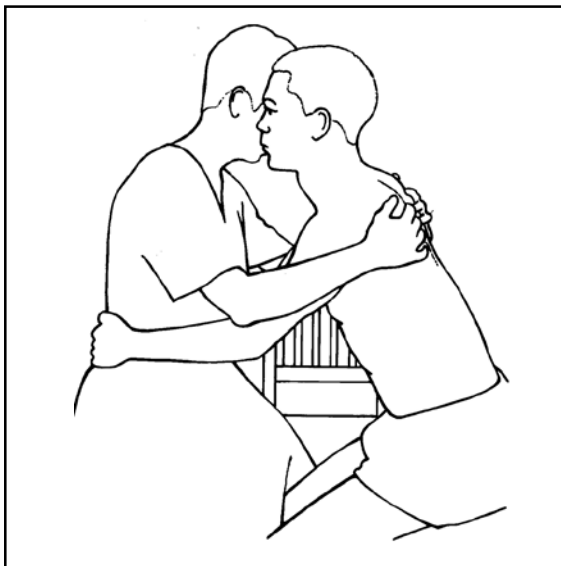

1. Ukususa umuntu esihlalweni umbeke esayidini likabhavu noma oqwembeni lokugezela.

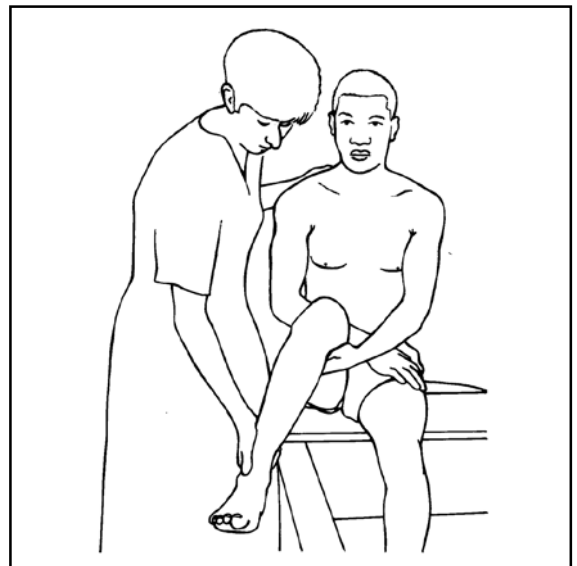

2. Makahlale oqwembeni lokugezela.
3. Phakamisa imilenze yakhe uyifake kubhavu.

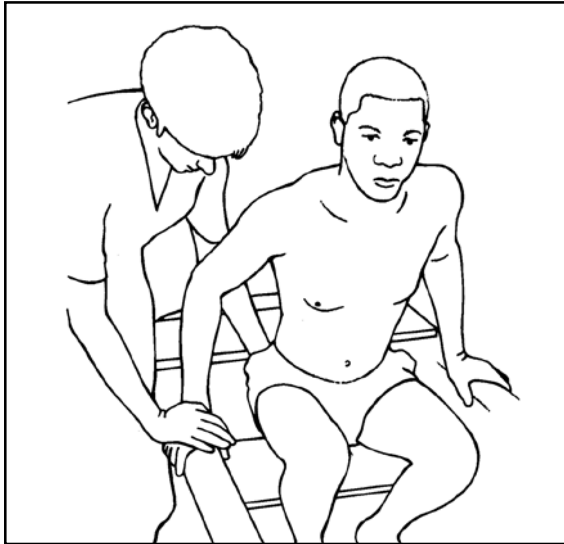

4. Mhlalise kwisihlalo sikabhavu. Makabambelele aqinise ngesandla esinamandla esayidini noma onqengemeni lukabhavu noma kwimigoqo yokubambelela. Isandla esibuthakathaka makasibeke emathangeni.
5. Makabambelele ngesandla esibuthakathaka onqengemeni lukabhavu noma kwimigoqo yokubambelela kubhavu uma enawo amandla.
6. Uma ebuthakathaka kangangokuthi ngeke ukwazi ukuhlala kubhavu, ungamlekelela ukuthi azigeze ngenkathi ehleli oqwembeni lokugezela. Angasebenzisa ishawa ephathwa ngesandla noma ishawa enanyathiselwe obondeni, enekhanda ongalehlisa noma ulikhuphule ukuze lilingane nobude bakhe.
7. Uma ekwazi ukwehlela ngaphansana kancane, sebenzisa isihlalo sikabhavu. Isihlalo sikabhavu kumele sibekwe kubhavu phakathi nendawo. Bheka izibonelo ezimbili zesihlalo sikabhavu ngezansi.



Izinto ezingasiza uma umuntu engakwazi ukuhlala phansi kubhavu wokugezela

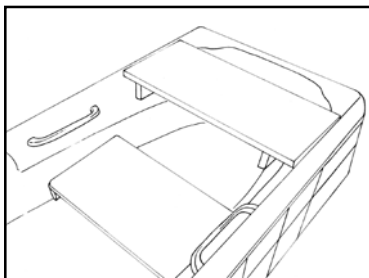

...qwembe lokugezela olubekwe phezu kukabhavu, kanye nesihlalo sikabhavu esibekwe ngaphakathi kukabhavu

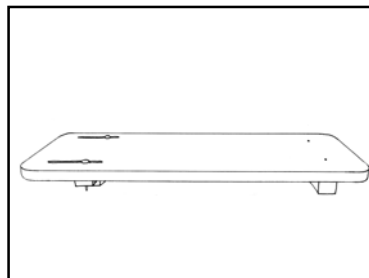

...qwembe lokugezela

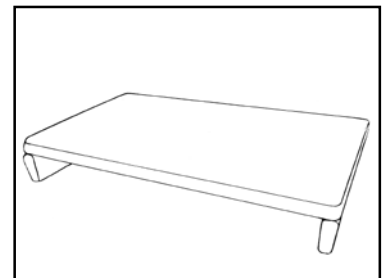

Isihlalo sikabhavu

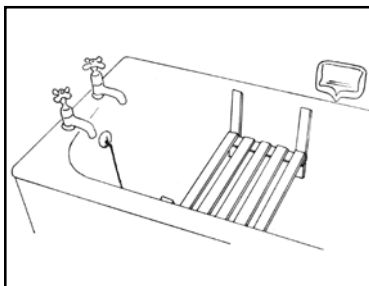

Isihlalo sikabhavu esinezikhala

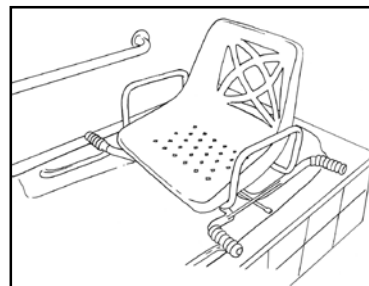

Isihlalo sikabhavu esiphendukayo

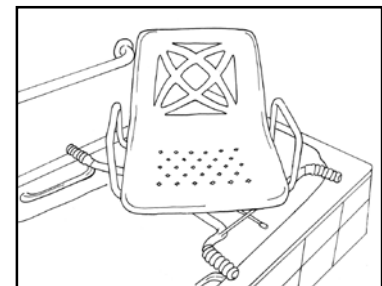

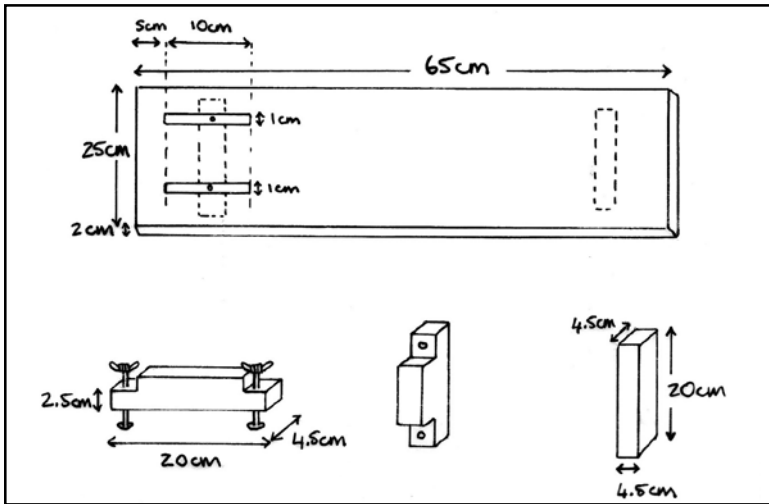

Isilinganiso sobude no-bubanzi boqwebwe lokugezela kanye neminingwane ephathelene nendlela yokwakha lolu qwebwe.

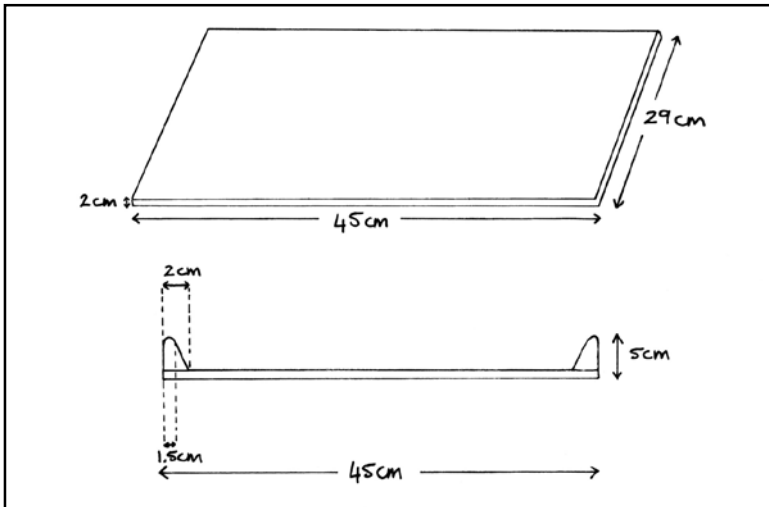

Isilinganiso sobude no-bubanzi besihlalo sikabhavu kanye neminingwane ephathelene nendlela yokwakha lesi sihlalo.

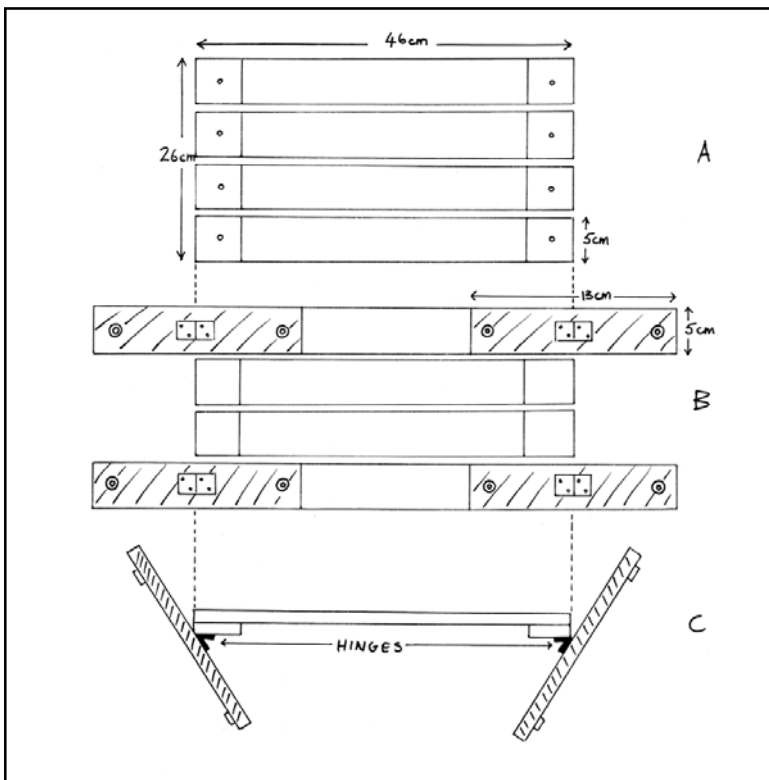

Isilinganiso sobude no-bubanzi besihlalo sikabhavu esinezikhala kanye neminingwane ephathelene nendlela yokwakha lesi sihlalo.

A. Umdwebo wesihlalo.

B. Umdwebo wamasayidi.

C. Indlela yokuhlanganisa isihlalo namasayidi.



Ngingambonisa kanjani umuntu indlela yokusuka esihlalweni ayongena kubhavu ngaphandle kokulekelelwa?

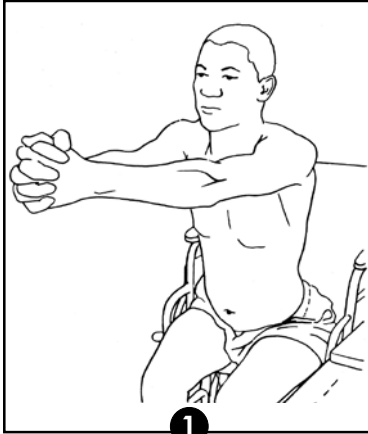

1

Hlanganisa izandla zakho bese usukuma ume ngezinyawo.

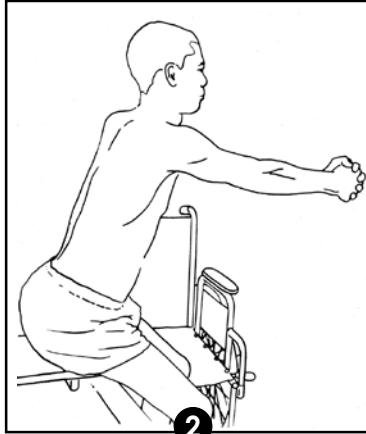

2

Phenduka bese uhlala phezu koqwembe lokugezela.

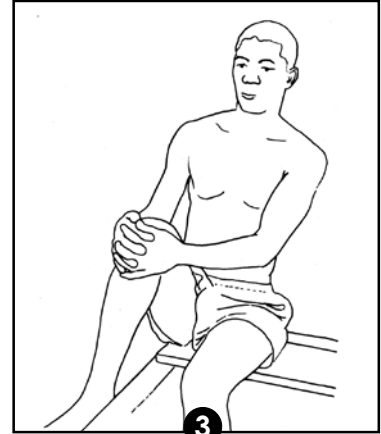

3

Bamba unyawo lwakho ngasedolweni bese uliphakamisa ulifake kubhavu.

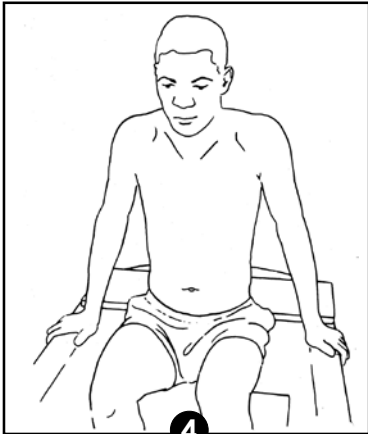

4

Bambelela ngezandla zakho onqenqemeni lukabhavu.

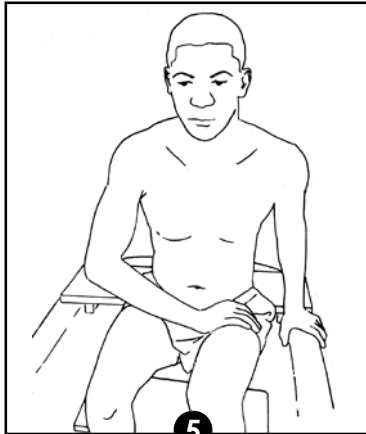

5

Uma isandla esibuthakathaka singenamandla kakhulu, sibeke ethangeni bese wehlisela umzimba wakho esihlalweni sikabhavu noma kubhavu uqobo lwawo.



6

Geza umzimba.

Insipho eboshwe ngentambo:



- Yenza imbobo ensiphweni. Bopha insipho ngentambo.
- Lengisa insipho emqaleni wakho ukuze ingaweli phansi noma iphunyuke.



- Beka ithawula elincane phezu kwedolo bese uligcoba ngensipho.

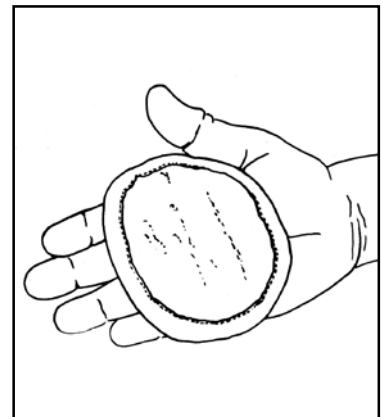

- Sebenzisa isiponji esinela-stiki ehamba ngasemuva kwesandla.

Indlela yokwenza ibhulashi lomhlane:

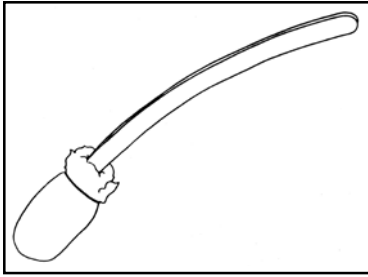

- Sebenzisa ihenga noma isiphanyeko sezingubo.
- Songa ngesiponji ingxenywe eyodwa yesidunu sehenga.
- Mboza isiponji ngethawula.



Iyiphi imihlahlandlela okumele ngiyilandele ukulekelela umuntu ukuthi agqoke?

Myeke azenzele ngokwakhe imisebenzana eminingi:

1. Umuntu kumele ahlale onqenqemeni lombhede, izinyawo zakhe azibeke phansi. Uma engakwazi ukuzimelela kahle embhedeni, mvumele ukuthi ahlale esihlalweni esinendawo yokuhlala eqinile kanye nendawo yokuqhiyama.
2. Makaqale ngokukhumula ngoba kona kulula.
3. Makasebenzise izingubo zokugqoka ezingampintshi.
4. Kumele asebenzise izingubo zokugqoka ezifaseka kalula.
5. Ukugqoka ngumsebenzi othatha isikhathi eside. Mnikeze isikhathi esanele.
6. Mkhuthaze ngokuthi umncome uma enze kahle.
7. Uma kunomsebenzi angakwazi ukuwenza aze awuphothule ngokuphelele, wuhlukanise ube yizinyathelwana ezincane, isibonelo njengokufaka kuphela izingalo emikhonweni. Kumele umlekelele kuphela uma kudingekile.
8. Kumele ngaso sonke isikhathi aqale ngokugqokisa uhlangothi olubuthakathaka, futhi kumele aqale ngokukhumula uhlangothi olunamandla.

Indlela yokugqoka ihembe noma ibhantshi

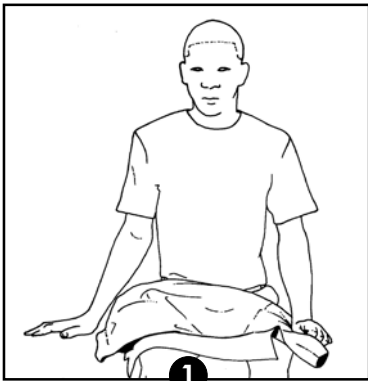

Makabeke ihembe emathangeni akhe. Ingxenywe engaphakathi kumele ibheke ngasenhla, kanti ukhololo wona kumele ubheke ngasemadolweni. Umkhono wengalo ebuthakathaka kumele ulenge phakathi kwemilenze.



Makasondeze ingalo ebuthakathaka ayibeke phezu kwamathanga.



Makafake isandla esibuthakatha embotsheni yomkhono.



Makadonse umkhono ukhuphuke ngesandla nengalo, size singabe sisabonakala isandla. Makaphonse ingxenywe esele yehembe emhlane.



Manje makadonse umkhono udlule endololwaneni.



Makadonse umkhono uye phezulu udlule phezu kwehlombe.



Makadonse ihembe lidlule ngasemuva emhlane.

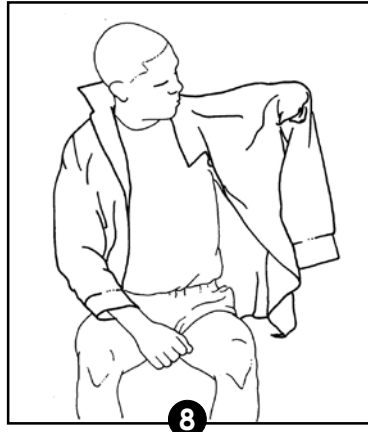

Makafake ingalo enamandla emkhonweni webhantshi.

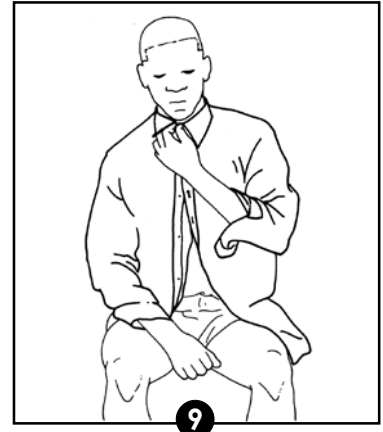

Makafase izinkinobho.

Indlela yokugqoka ibhulukwe



Makabeke ibhulukwe ngasohlangothini lwakhe olunamandla.



Makagaxanise imilenze yakhe, umlenze obuthakathaka awubeke phezu komlenze onamandla.



Makafake unyawo olubuthakathaka emlenzeni webhulukwe.



Makakhuphule ibhulukwe lidlule phezu kwamadolo bese ehlukanisa imilenze yakhe.



Manje makafake umlenze onamandla emlenzeni webhulukwe.

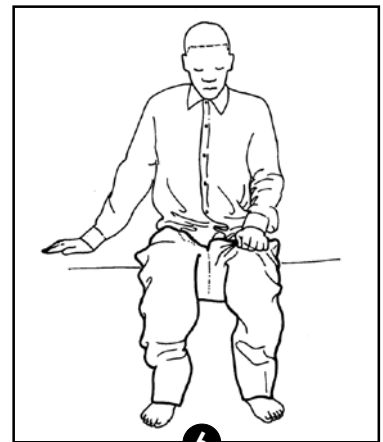

Makadonse ibhulukwe lidlule emadolweni.

Uma umuntu ebuthakathaka kakhulu

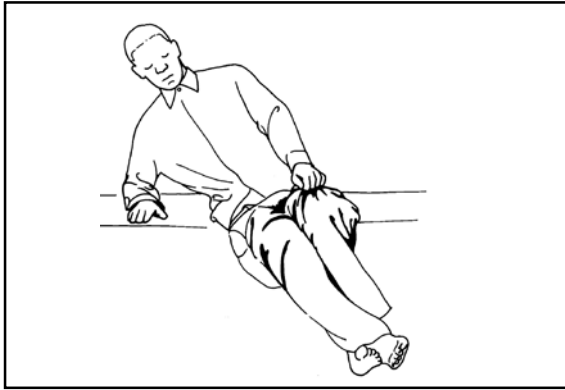

1. Makakhuphule ibhulukwe lidlule phezu kwemilenze ngokuthi agaxe unyawo olunamandla ngaphansi konyawo olubuthakathaka, azimelele ngendololwane, bese elala ngomhlane phezu kombhede.

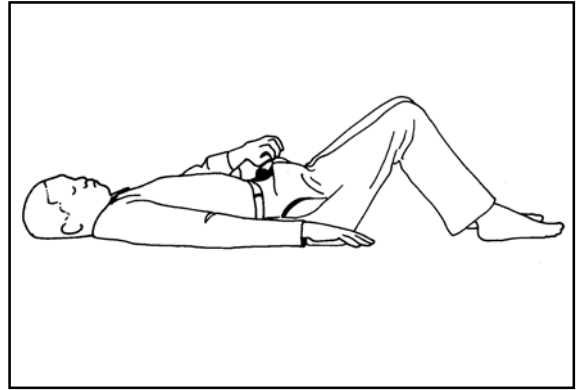

2. Makagobise amadolo.
3. Makaphakamise isinqe sakhe.
4. Makadonse ibhulukwe phezu kwesinqe.
5. Makabeke isinqe phezu kombhede.
6. Manje usengawufasa uziphu kanye nebhande.
7. Makasukume ame ngezinyawo futhi.

Uma umuntu ekwazi ukuma ngezinyawo zakhe, uma elekelelwa

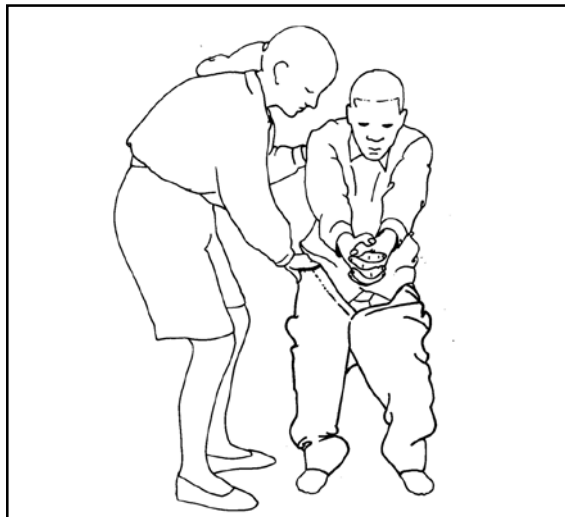

1. Makasukume ame ngezinyawo zakhe ngenkathi elekelelwa (umnakekeli kumele ame ngasohlangothini olubuthakathaka).
2. Umuntu angazimelela ngokubeka ingalo yakhe phezu kwesihlalo noma kwenye impahla eyifenisha.
3. Umnakekeli ukhuphula ibhulukwe.

Uma umuntu ekwazi ukuzimela ngezinyawo zakhe ngaphandle kokulekelelwa



Makasukume ame ngezinyawo ukuze akhuphule ibhulukwe lidlule esinqeni bese efasa uziphu abophe nebhande.

Indlela yokugqoka ijezi



1. Umuntu ubeka ijezi emathangeni, umhlane wejezi ube ngaphezulu, bese isingezansi sejezi sibheke ngasemzimbeni. Umaqala wejezi kumele uhlale phezu kwamadolo.



2. Makavule isingezansi sejezi.
3. Makathole imbobo yomkhono okuzongena kuyona ingalo ebuthakathaka.



4. Makabeke umkhono phakathi kwamadolo.
5. Imbobo yomkhono makayigcine ivulekile ngokusebenzisa isandla sakhe esinamandla.



6. Makafake isandla esibuthakathaka embotsheni yomkhono.

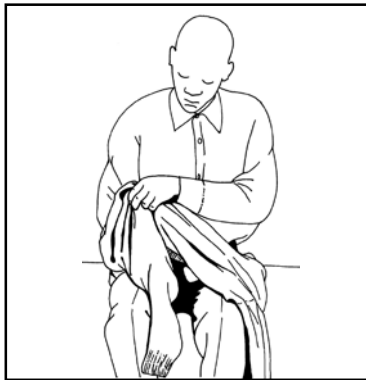

7. Manje makadonse umkhono awudlulise phezu kwendololwane.



8. Manje makadonse umkhono udlule phezu kwengxenye yengalo engenhla kwendololwane.



9. Makakhuphule ijezi lidlule phezu kwehlombe.



10. Manje ingalo enamandla ingena emkhonweni.



11. Kulandele ikhanda.

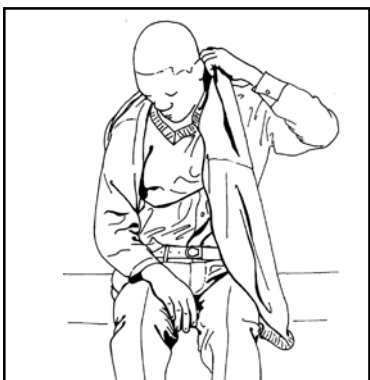

12. Uma ethanda angafaka ikhanda kuqala.



13. Bese elandelisa ngeingalo enamandla.

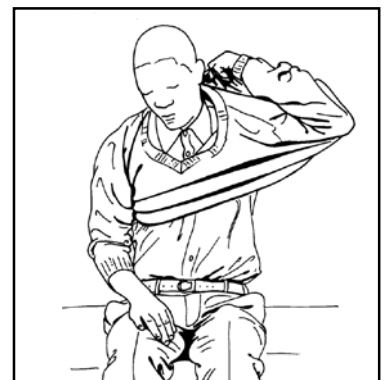

14. Ekugcineni, udonsa ingxenye engemuva ukuze ihlale kahle.

Indlela yokugqoka amasokisi

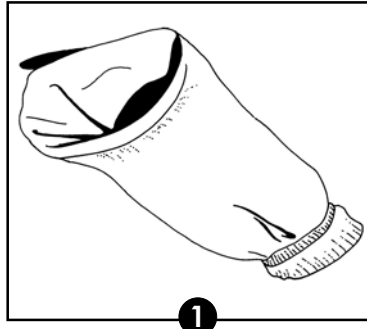

Sebenzisa amasokisi anwebekayo kakhulu. Isigamu noma uhhafu wesokisi kumele ugoqwe uze ufinyelele eqakaleni lesokisi.



Makagaxe unyawo olubuthakathaka phezulu konyawo olunamandla.

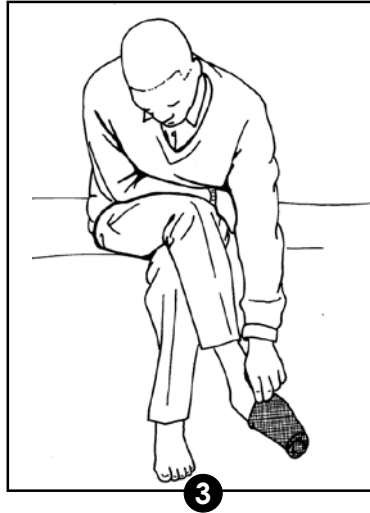

Emva kwalokho makadonse isokisi phezu kwezinzwane.

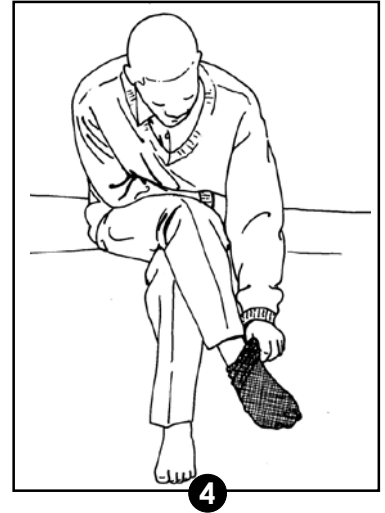

Bese elikhuphula isokisi phezulu konyawo neqakala.

Indlela yokugqoka izicathulo

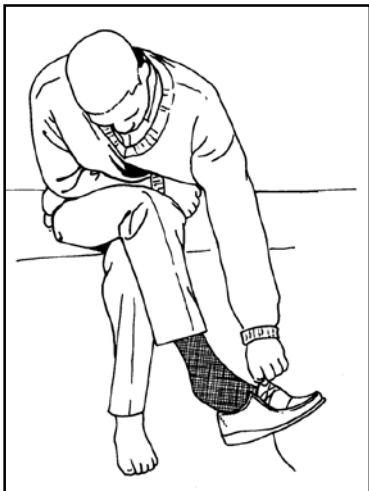

1. Makagaxe unyawo olubuthakathaka phezulu konyawo olunamandla.
2. Bese edonsa isicathulo sibe phezulu kwezinzwane. Kumele asebenzise izicathulo ezingenamafosi noma ezifaswa ngezinamathelisi zohlobo lwe-Velcro.

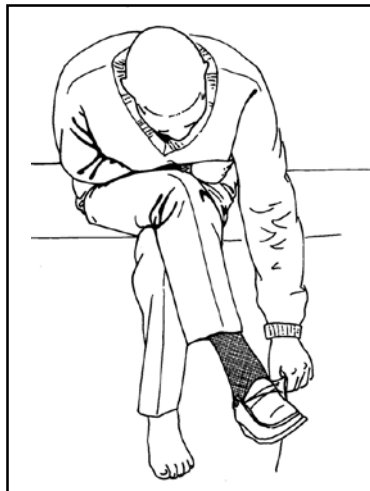

3. Faka unyawo phakathi esicathulweni.

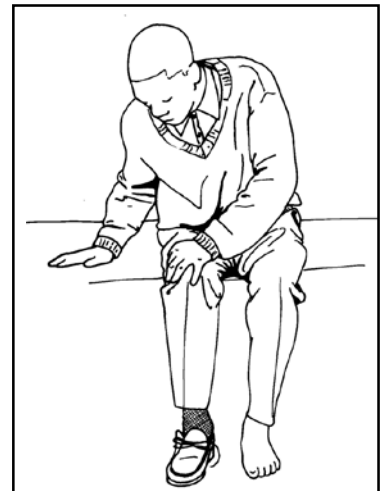

4. Manje makalubeka phansi unyawo bese ecindezela idolo ngesandla ukuze isithende singene esicathulweni.

Ukuhambahamba ngokulekelelwa ngomunye umuntu



Iyiphi indlela efanelekile yokulekelela umuntu ukuthi akwazi ukuzihambela ngezinyawo zakhe?

Imigomo ejwayelekile:

1. Msekele ngasohlangothini olubuthakathaka.
2. Beka inqulu yakho ngasemuva kwenqulu yakhe ebuthakathaka.
3. Unyawo lwakho lungalulekelela unyawo lwakhe olubuthakathaka, uma kunesidingo.
4. Mbambe umqinise ngesandla esisodwa emzimbeni.
5. Lesi esinye isandla kumele sibambe isandla sakhe. Uma umuntu engenamandla, beka isandla sakho esingasebenzile esiswini sakhe ukuze umbambe umqinise phakathi kwezingalo zakho.
6. Mnikeze ithuba nesikhala esanele sokuthi acondobezele.
7. Uma useduze kakhulu kwakhe noma uma umqinise kakhulu, nobabili nizokuthola kunzima ukuma ngezinyawo niqonde futhi ngeke kube lula ukuthi azihambele ngezinyawo zakhe.

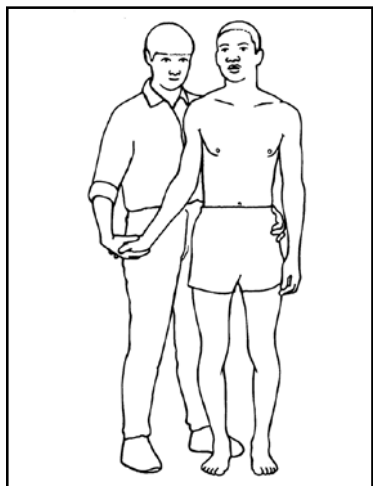

Ngaphambili.

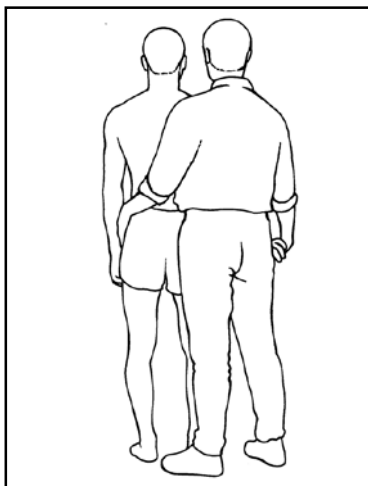

Ngasemuva.



Uma umuntu ebuthakathaka kakhulu, sebenzisa udondolo ngasohlangothini lwakhe olunamandla. Bobabili, umnakekeli kanye nomuntu ogulayo, kumele bagqoke izicathulo ezinethezekile, eziqinile futhi ezingasheleli noma bahambe ngezinyawo bengagqokile amasokisi nezicathulo. Kumele bangalokothi bahambe phansi ngamasokisi!

Indlela efanelekile yokumbamba:

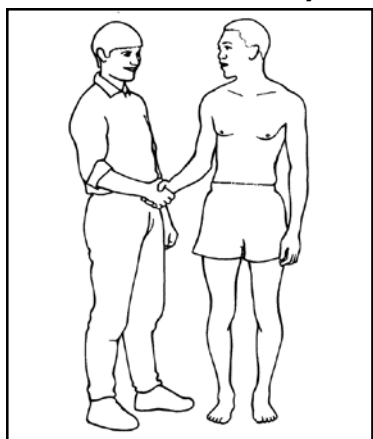

1. Qala sengathi uya-mxhawula, kodwa uphendule intende yesandla sakho uyibhekise phezulu ngenkathi ubambe isandla sakhe.
2. Bamba isandla esibuthakathaka.
3. Ungamdonsi ngengalo yakhe ebuthakathaka.

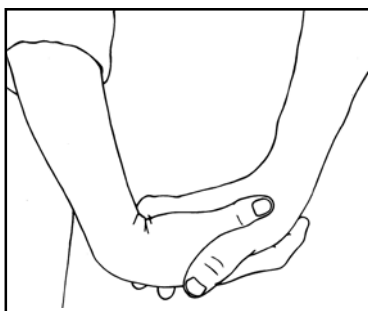

4. Sekela ingalo ngokucindezela isandla usibhekise phezulu.
5. Indololwane kumele iqonde, incike emzimbeni wakho. Ngale ndlela, ingalo izohlala iqondile futhi umuntu angancika esandleni sakho ukuze athole ukusekeleka. Lokhu kuyamsiza futhi ukuthi akwazi ukuma aqonde.

Enye indlela yokumbamba:

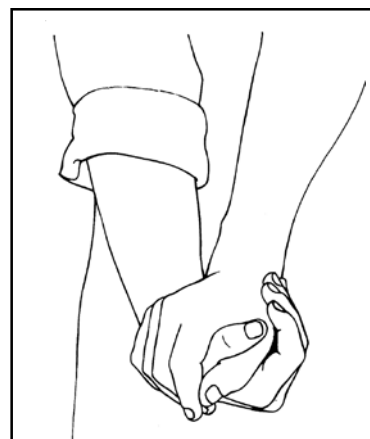

Lena yindlela enhle kakhulu ongayisebenzisa ukubamba umuntu onesihlakala esingogobe.

1. Gaxa isithupha sakho kwesakhe.
2. Bamba isandla sakhe ngaphansi kwesithupha.
3. Qinisekisa ukuthi abukho ubuhlungu abuzwayo esihlakaleni sakhe.

11.

Izinkinga ezivamisile emva kokuhlaselwa yisifo sohlangothi

Inkinga	Indawo noma umuntu ozothola kuyena usizo	Igama kanye nemininingwane yokuxhumana nezinkampani noma izihlangano ezihlinzeka ngosizo ezitholakala endaweni yakini
Izinhlungu ehloambe/izinhlungu ehloambe nasesandleni	Physiotherapist (isisebenzi sezempilo eselapha iziguli ebezilimele noma ebezihlaselwe ukugula okubangela ukukhubazeka okuthile) /occupational therapist	
Izifo eziphathelene nomgudu womchamo (isinye)	Emtholampilo/kudokotela/kumhlengikazi	
Ukuqunjelwa/Uhudo	Emtholampilo/kudokotela/kumhlengikazi	
Ukuputshuka noma ukuwa esihlalweni esinamasondo	Umtholampilo wezokuhlala/isisebenzi sezempilo esiqeqeshiwe kwezizihlalo ezinamasondo kanye nokuhlala/physiotherapist/occupational therapist	
Izinkinga eziphathelene nokuziphatha	Occupational therapist/clinical psychologist/usonhlalakahle	
Ukushiswa (ukubindwa noma ukukhwehlela emva kokugwinya)	Umelaphi wezinkinga eziphathelene nokukhuluma/umhlengikazi	
Izilonda ezibangelwa ukulala kakhulu embhedeni	Emtholampilo/kudokotela/kumhlengikazi kanye nakwi-physiotherapist/occupational therapist	
Ukufinyela kwezicubu zomzimba/ukuqina kwezicubu zomzimba/inkwantshu	Physiotherapist(isisebenzi sezempilo eselapha iziguli ebezilimele noma ebezihlaselwe ukugula okubangela ukukhubazeka okuthile)	
Ingcindezi yomphefumulo	Emtholampilo/kudokotela/occupational therapist/kusonhlalakahle	
Ukubona sengathi izinto ziphindaphindeke kabili noma ukubona kuphela ngohlangothi olulodwa	Emtholampilo/kudokotela wamehlo/occupational therapist	



Qinisekisa ukuthi umuntu onesifo sohlangothi uwadla ngendlela efanelekile amaphilisi nemithi yakhe.

Amazwi okubonga

Ababhali bathanda ukudlulisa amazwi okubonga kulaba abalandelayo, ngoba leli bhukwana belingeke neze lishicilelwe ngaphandle kosizo lwabo:

1. U-Jenny Hendry, okuwuyena owaqalisa le phrojekthi, owalekelela emizamweni yokunxena abatshali-zimali ukuthi baxhase lo mklamo, owadlala indima enkulu esigabeni sokuhlela, futhi wafaka isandla ngenkathi kuhlolenjiswa leli bhukwana okokugcina.
2. UGubela Mji ngokuyamukela ngazo zombili le phrojekthi eyithatha ku-Jenny Hendry, kanye nokuhlinzeka ngogqozi nofuqufuqu ngokuqhubekayo.
3. U-Deona Roets ngegalelo lakhe kwingxenye yaleli bhukwana ephathelene nenkulumo kanye nokugwinya.
4. Uphiko olwabe lubizwa ngoMnyango Wezamazinyo lwase-Tygerberg ngokuhlinzeka ngamifanekiso kanye nolwazi oluphathelene namazinyo kanye nokunakekelwa komlomo.
5. U-Andrienne Human, ongumthwebuli-zithombe, ngokubekezela kwakhe kanye noku-gcizelela ukuthi kwenziwe umsebenzi oseqophelweni eliphezulu.
6. Imifanekiso yemidwebo: Neels Olivier, Jeanette Oliphant, Christa Prins, Deona Roets, Lynette Vorster, Elizabeth Brandt, Susan Human, Maria Britz kanye no-Mandy Smith.
7. UMnyango Wezobuciko: Ophikweni lwase-Tygerberg, lweNyuvesi yase-Stellenbosch, ngokuhlinzeka ngemidwebo yokuqala.
8. U-Kim McDonald ngokuhlinzeka ngemidwebo eyabe isilele, ngobunyoinco obukhulu, eqhubeka lapho kwashiya khona abadwebi ababenza lo msebenzi phambilini.
9. U-Sheena Irwin-Carruthers, Helen Sammons kanye no-Jacqui Goeller ngokufundisisa umkhiqizo wokugcina waleli bhukwana ukuqinisekisa ukuthi awunamaphutha.
10. Abantu abanesifo sohlangothi, imindeni yabo kanye nabanakekeli babo ngemibono yabo kanye nolwazi abaluhlinzekile esigabeni sokuthuthukiswa kwaleli bhukwana.
11. Abantu ababebambe iqhaza ezifundweni ezimbili ezadonsa isikhathi esingamaviki amathathu zohlelo oluyisisekelo lwabantu abadala lwe-Bobath ngowezi-2010 futhi ababamba iqhaza kwinqubo ehlelekile yokuhlolwa ngontanga.

Ukubonga okukhethekile kudluliselwa kwabakwa-BoehringerIngelheim ngokuxhasa ngezi-mali umsebenzi wokuhlembisa ushicilelo lowezi-2015 kanye nokuluhumushela kulezi zilimi, isiBhunu, Sesotho, isiXhosa kanye nesiZulu.



**Boehringer
Ingelheim**



Kungani sibhale leli bhukwana?

Isifo sohlangothi yisifo esiyimpicabadala, futhi ukunakekela umuntu onalesi sifo kuyinselelo enkulu. Okwenza lesi simo sibe sibi kakhulu ukuthi zincane kakhulu izikhungo zomphakathi ezikhona njengamanje ezihlinzeka ngosizo lokwela-pha abantu abahlaselwe yilesi sifo. Abantu abanengi abalaliswa nokulaliswa esibhedlela emva kokuhlaselwa yisifo sohlangothi, futhi esikhathini esiningi labo abalaliswayo bakhululwa kungakapheli ngisho amahora angama-48.

Abanakekeli basemakhaya abakutholi ukuqeqeshwa okwanele futhi abasekelwa ngendlela efanele, futhi kubhe-keke ukuthi benze konke okusemandleni abo ngaphansi kwaleso simo. Abanakekeli bahlangabezana nobunzima bokuxhumana ngendlela efanele nomuntu onesifo sohlangothi futhi kwesinye isikhathi abaziqondi izinkinga ezipha-thelene nokuziphatha ezibangelwa yisifo sohlangothi. Bakuthola kunzima ukulekelela abantu abanakesifo sohlangothi emisebenzini efana nokubagqokisa kanye nokubasusa endaweni ethile bababeke kwenye. Lokhu kuholela ekutheni kube nezinkinga, empeleni ebezingagwemeka kalula, ezinjengokuphathwa yizinhlungu emahlombe nasezandleni, ukufinyela nokugongobala kwemisipha nezicubu zomzimba kanye nemikhutshana yokuziphatha ngendlela engafanele.

Ngonyaka we-1995, sathola usizo lokuxhaswa ngezimali oluvela kwinkampani eyabe ibizwa nge-Portnet phambilini, njengengxenywe yoHlelo Lokuhlela Kabusha Nokuthuthukisa ukuze kuthuthukiswe futhi kwenziwe iphakheji yokuqeqe-sha, ebandakanya uhlelo lokuqeqesha oluthatha amahora amane olwenzelwe ukuqeqesha abanakesifo sohlangothi emisebenzini kanye nezinye zikhungo zokunakekela, njengamakhaya abantu abadala, futhi ukuze kuthuthukiswe ibhukwana lokuqeqesha elisekela futhi ligxile kakhulukwimikhakha ephathelene nekho lokwenza lokho okufun-dwe ezifundweni zokuqeqesha. Lolu hlelo oluphelele lokuqeqesha lwathuthukiswa ngokubambisana phakathi kwesiKhungo Sezifundo Zokwelashwa Kwabantu Abanokukhubazeka seNyuvesi yase-Stellenbosch kanye nesiKhu-ngo Sokwelashwa Kwabantu Abakhubazekile saseNtshonalanga Kapa.

Esikhathini esiyiminyaka eyishumi, lolu hlelo oluphelele lwenziwe ngcono futhi lwaguqulwa ukuze luhambelane nezidingo nemibono ezwakaliswe ngabantu abaqeqeshwayo kanye nabantu abanesifo sohlangothi. Ukuba se-simweni esifanelekile kwaleli bhukwana kwahlolwa futhi kwacutshungulwa njengengxenywe yocwaningo lweziqu ze-masters nguDkt Janine Botha. Izincomo ezatholakala kulolu cwaningo nazo zisetshenzisiwe ukuhlanganisa leli bhukwana. Leli bhukwana eliphelele manje seliyatholakala.

Ababhali banethemba lokuthi leli bhukwana lizohlinzeka abanakekeli ngomhlahlandlela olula futhi ofinyeleleka ka-lula abangawusebenzisa ukuthola ulwazi abaludingayo ekhaya mayelana nokunakekela umuntu ohlaselwe yisifo sohlangothi. Leli bhukwana alenzelwe ukuthatha indawo yokuqeqeshwa, kepha lenzelwe ukuthi lisetshenziswe ngabanakekeli ngenhloso yokuzikhumbuza lokho abafundiswe kona emva kokuphothula ukuqeqeshwa kwabo. Abanakekeli kudingeka ukuthi bachithe isikhathi esanele ekuqeqeshweni kwabo ukuze kuqinisekise ukuthi bana-makhono anele futhi afanelekile.

IsiKhungo Sezifundo Zokwelashwa Kwabantu Abanokukhubazeka, eNyuvesi yase-Stellenbosch

IsiKhungo Sezifundo Zokwelashwa Kwabantu Abanokukhubazeka sihlizeka abasebenzi bomkhakha wezempilo, kanye nabeminye imikhakha ehlobene nawo, ngeziqo zohlobo lwe-post-graduate (MSc/MPHil) eziyingqayizivele emkhakheni wezokwelashwa kwabantu abanokukhubazeka. Le ndlela yokufundisa ihlanganisa imikhakha enhlo-bonhlobo, futhi igxile ekuthuthukisweni kwamakhono obuholi ukuze kuqinisekise ukuthuthukiswa, ukuphatha, nokuhlola kanye nocwaningo olufanelekile futhi olungambi eqolo, oluphathelene nokwelashwa kwabantu abanokukhubazeka kanye nezinhlelo eziphathelene nokukhubazeka. IsiKhungo Sezifundo Zokwelashwa Kwabantu Abanokukhubazeka sidlala futhi indima yokusekela ukuthuthukiswa kohlelo lwezifundo oPhikweni Lwamasayensi Ezempilo kanye Nokwelapha, mayelana nezinto eziphathelene nokukhubazeka kanye nokwelashwa kwabantu abanokukhubazeka okuthile.

Lesi siKhungo siyingqayizivele ekuhlinzekeni ngezinhlelo ezinohlonze zemfundo nokuqeqesha kwezokwelashwa kwabantu abanokukhubazeka futhi sihlizeka ngamathuba ezocwaningo nosizo kubasebenzi bezempilo kuwo wonke amazinga ezempilo kanye nasemphakathini, aphathelene nawo wonke amasayensi ezempilo kanye nezinto eziphathelene nokwelashwa kwabantu abanokukhubazeka.

<http://www.sun.ac.za/crs>

IsiKhungo Sokwelashwa Kwabantu Abanokukhubazeka Emzimbeni saseNtshonalanga Kapa

IsiKhungo Sokwelashwa Kwabantu Abanokukhubazeka Emzimbeni saseNtshonalanga Kapa (WCRC) sizibophezele ekuqinisekiseni ukwelashwa kwabantu abanokukhubazeka ngendlela efanelekile futhi esebenza kahle. Thina sihlizeka ngezinhlelo ezinohlonze zokwelashwa kwabantu abanokukhubazeka, njengeziguli ezilashelwa ngaphakathi noma ezilashelwa emakhaya ukuze kukhuthazwe amakhasimende ethu ukuthi akwazi ukubamba iqhaza ngokuphelele emphakathini. Izimpawu ezibalulekile zomsebenzi wethu zibandakanya ukubeka amakhasimende phambili, indlela yokusebenza esekelwe phezu kwemiphumela kanye nokubambisana kwabasebenzi bethu nje-ngeqembu eliyimbumba elenza imisebenzi enhlobonhlobo futhi emikhakheni enhlobonhlobo.

I-WCRC inemibhede eyi-156 yokulalisa iziguli ezilashelwa ngaphakathi. Amakhasimende ethu alaliswayo avela ezibhedlela zikahulumeni kanye nezizimele futhi amukelwa ngokushesha emva kokuthi sesizinzile isimo sawo seze-mpilo futhi uma esekwazi ukubamba iqhaza ngenkuthalo ezinhlelweni zethu zokwelashwa kwabantu abanokukhubazekile. Usizo esilunikeza iziguli ezilashelwa ngaphandle lubandakanya ukuhlololwa izifo nokuxilongwa, ukwelashwa kokulandelela, imitholampilo ekhethekile kanye nezinhlelo zokusiza nokuqwashisa umphakathi.

Inhloso-mbono ye-WCRC ukuba yisikhungo esihamba phambili emhlabeni emkhakheni wezokwelashwa kwabantu abanokukhubazeka emzimbeni.

<http://www.wcrc.co.za>

